

Quick Start  
Guide

# HP 81101A 50 MHz Pulse Generator

# Front Panel Display and Softkeys

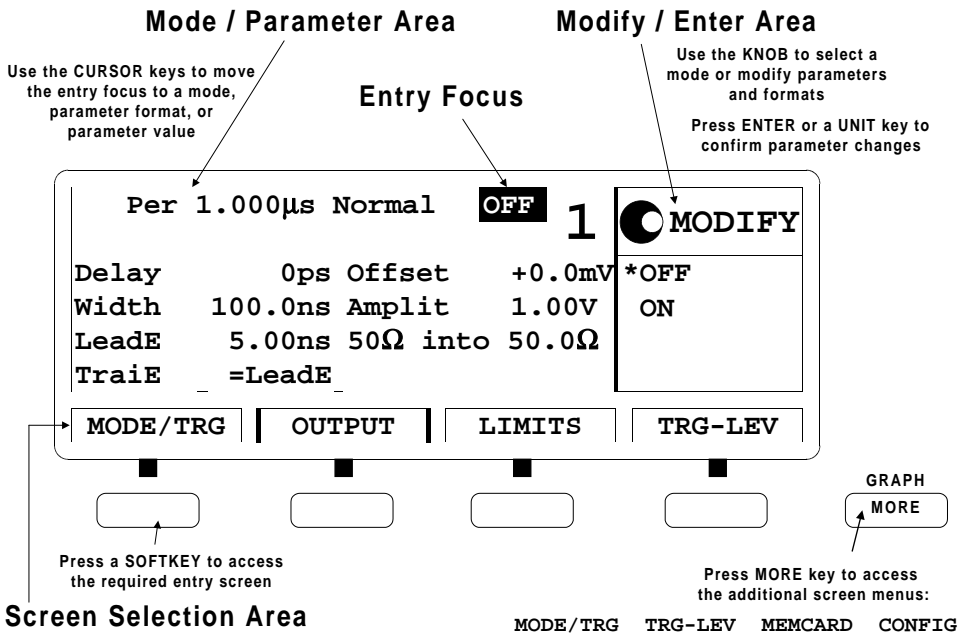

**Quick Start Guide**

**HP 81101A 50 MHz**  
**Pulse Generator**

**HP Part No. 81101-91010**  
**Printed in Germany September 1998**  
**Edition 1.0, E0998**

# Notice

## Copyright

© 1998 Hewlett-Packard GmbH

Herrenberger Str. 110–140

71034 Boeblingen

Germany

All rights reserved. Reproduction, adaptation or translation without prior written permission is prohibited, except as allowed under the copyright laws.

## Warranty

This Hewlett-Packard product has a warranty against defects in material and workmanship for a period of three years from date of shipment. During the warranty period, Hewlett-Packard Company will, at its option, either repair or replace products that prove to be defective. For warranty service or repair, this product must be returned to a service facility designated by Hewlett-Packard. The Buyer shall pay Hewlett-Packard's round-trip travel expenses. For products returned to Hewlett-Packard for warranty service, the Buyer shall prepay shipping charges to Hewlett-Packard and Hewlett-Packard shall pay shipping charges to return the product to the Buyer. However, the Buyer shall pay all shipping charges, duties and taxes for products returned to Hewlett-Packard from another country. Hewlett-Packard warrants that its software and firmware designated by Hewlett-Packard for use with an instrument will execute its programming instructions when properly installed on that instrument. Hewlett-Packard does not warrant that the operation of the instrument software, or firmware, will be uninterrupted or error free.

## **Limitation of Warranty**

The foregoing warranty shall not apply to defects resulting from improper or inadequate maintenance by the Buyer, Buyer-supplied software or interfacing, unauthorized modification or misuse, operation outside of the environmental specifications for the product, or improper site preparation or maintenance.

No other warranty is expressed or implied. Hewlett-Packard specifically disclaims the implied warranties of merchantability and fitness for a particular purpose.

## **Exclusive Remedies**

The remedies supplied are the Buyer's sole and exclusive remedies. Hewlett-Packard shall not be liable for any direct, indirect, special, incidental, or consequential damages, whether based on contract, tort or any other legal theory.

## **Assistance**

Product maintenance agreements and other customer assistance agreements are available for Hewlett-Packard products. For any assistance, contact your nearest Hewlett-Packard Sales Office.

## **Certification**

Hewlett-Packard Company certifies that this product met its published specifications at the time of shipment. Hewlett-Packard further certifies that its calibration measurements are traceable to the United States Institute of Standards and Technology, to the extent allowed by the Institute's calibrating facility, and to the calibration facilities of other International Standards Organization members.

## About this Book

This quick start guide helps you to quickly get familiar with the features and the user interface of the HP 81101A Pulse Generator.

*Chapter 1 “Introducing the HP 81101A Pulse Generator” on page 15* gives a general overview of the HP 81101A, its features, the user interface, and the steps required for operating the instrument.

For getting started *Chapter 2 “Getting Started” on page 29* gives the setup information for some real-world signal examples, which can easily be used by varying only some parameter values.

*Chapter 3 “Using the HP 81101A” on page 43* provides complete information on the user interface screens.

Installation and maintenance are described in *Appendix A “Installation & Maintenance” on page 75*.

For specifications and information on operating the instrument by means of remote control, please refer to the *Reference Guide*, p/n 81101-91011.

## Conventions Used in this Book

This book uses certain conventions to indicate elements of the HP 81101A's user interface. The following table shows some examples:

---

Softkeys	Press the MODE/TRG softkey to access the Mode/Trigger screen.
Hardkeys	Press the MORE key to switch to the alternative softkey layout.
Alternate Keys	Press SHIFT + 0 (ON/OFF) to switch on the output. The alternate key label—which is selected by pressing the SHIFT key—is given in parentheses.
Screen Quotes	Move the entry focus down to PULSE-PERIOD and turn the knob to select INTERNAL PLL.
Entry Focus	The highlight field, that can be moved with the cursor keys, to change modes, parameters, or parameter formats.

---

# Safety Information

## Safety

This is a Safety Class 1 instrument (provided with terminal for protective earthing). Before applying power, verify that the correct safety precautions are taken (see the following warnings). In addition, note the external markings on the instrument that are described under Safety Symbols. Do not operate the instrument with its covers removed. Replace fuse only with specified type.

## Warning

Before turning on the instrument, you must connect the protective earth terminal of the instrument to the protective earth conductor of the (mains) power cord. The mains plug must only be inserted in a socket outlet with a protective earth contact. Do not negate the protective action by using an extension power cord without a protective grounding conductor. Grounding one conductor of a two-conductor outlet is not sufficient protection.

Service instructions are for trained service personnel. To avoid dangerous electric shock, do not perform any service unless qualified to do so. Do not attempt internal service or adjustment unless another person, capable of rendering first aid and resuscitation, is present.

If you energize this instrument using an auto-transformer (for voltage reduction), make sure that the common terminal is connected to the earth terminal of the power source.

Whenever it is likely that the ground protection is impaired, you must make the instrument inoperative and secure it against any unintended operation.

Do not operate the instrument in the presence of flammable gases or fumes. Operation of any electrical instrument in such an environment constitutes a definite safety hazard.

Do not install substitute parts or perform any unauthorized modification to the instrument.



Capacitors inside the instrument may retain a charge even if the instrument is disconnected from its source of supply.

### Safety Symbols



Instruction Manual symbol: The instrument is marked with this symbol when it is necessary for you to refer to the instruction manual in order to protect against damage to the instrument.



Protected conductor symbol.

In the manuals:

---

#### **WARNING**

---

**Warnings call attention to a procedure, practice, or the like, which, if not correctly performed or adhered to, could result in personal injury or loss of life. Do not proceed beyond a Warning until the indicated conditions are fully understood and met.**

---

#### **CAUTION**

---

Cautions call attention to a procedure, practice, or the like, which, if not correctly performed or adhered to, could result in damage to or destruction of part or all of the equipment. Do not proceed beyond a Caution until the indicated conditions are fully understood and met.

**Safety Information**

# Contents

	<b>Notice .....</b>	<b>4</b>
	<b>About this Book .....</b>	<b>6</b>
	<b>Safety Information .....</b>	<b>8</b>
Chapter 1	<b>Introducing the HP 81101A Pulse Generator</b>	
	<b>What you can do with the HP 81101A .....</b>	<b>16</b>
	<b>The Front Panel .....</b>	<b>18</b>
	<b>Operating the HP 81101A .....</b>	<b>20</b>
	Switching On the Instrument .....	20
	The Basic Screens .....	21
	Adjusting Parameters .....	23
	Switching the Output On and Off .....	26
	Using the Special Function Keys .....	26
	<b>Help is Available .....</b>	<b>27</b>
	<b>The Rear Panel .....</b>	<b>28</b>
Chapter 2	<b>Getting Started</b>	
	<b>Setting Up a Clock Signal .....</b>	<b>30</b>
	<b>Setting Up a Pulse Signal .....</b>	<b>35</b>
	<b>Setting Up a Burst Signal .....</b>	<b>39</b>

# Contents

## Chapter 3 Using the HP 81101A

<b>The Mode/Trigger Screen .....</b>	<b>44</b>
Overview .....	44
Continuous Pulses Mode .....	46
Continuous Burst Mode .....	47
Triggered Pulses Mode .....	48
Triggered Burst Mode .....	50
Gated Pulses Mode .....	52
Gated Burst Mode .....	54
External Width Mode .....	55
<b>The Output Screen .....</b>	<b>56</b>
Timing Parameters .....	56
Level Parameters .....	61
<b>The Limits Screen .....</b>	<b>64</b>
<b>The Trigger-Level Screen .....</b>	<b>65</b>
Threshold and Impedance Parameters .....	65
Trigger and Strobe Level Parameters .....	66
<b>The Memory Card Screen .....</b>	<b>67</b>
<b>The Configuration Screen .....</b>	<b>70</b>
<b>Warnings and Errors .....</b>	<b>72</b>

# Contents

Appendix A	<b>Installation &amp; Maintenance</b>	
	<b>Initial Inspection</b> .....	<b>76</b>
	Standard Deliverables .....	77
	Options and Accessories: .....	78
	<b>Power Requirements</b> .....	<b>80</b>
	<b>Power Cable</b> .....	<b>82</b>
	<b>Ventilation Requirements</b> .....	<b>83</b>
	Thermal Protection .....	83
	<b>Battery</b> .....	<b>84</b>
	Battery Replacement .....	85
	<b>Operating Environment</b> .....	<b>86</b>
	<b>Cleaning Recommendation</b> .....	<b>87</b>
	<b>Acoustic Noise Emission</b> .....	<b>88</b>

# Contents

---

# 1

---

## Introducing the HP 81101A Pulse Generator

The purpose of the introduction chapter is to give a general overview of the HP 81101A.

The main features and use models are described in *“What you can do with the HP 81101A” on page 16.*

Operating the instrument via the front panel user interface is described in *“The Front Panel” on page 18* and *“Operating the HP 81101A” on page 20.*

*“Help is Available” on page 27* shortly introduces the HP 81101A’s on-line help system.

Finally, *“The Rear Panel” on page 28* takes a look at the back of the HP 81101A.

## What you can do with the HP 81101A

This section introduces the basic features and use models of the HP 81101A Pulse Generator.

### Basic Features

The HP 81101A is a single-channel pulse generator with variable transition times. It is capable of generating all standard pulses and bursts of pulses needed to test current logic technologies (for example, TTL, CMOS, ECL, PECL, LVDS, GTL) and other digital designs up to 50 MHz.

The instrument features two internal oscillators:

- a synchronously triggerable internal oscillator
- an accurate, stable internal PLL

For even more accuracy, an external frequency reference can be connected.

Any timing parameter can be varied without glitch or drop out. This contributes to more accurate and confident characterizations of the device under test (DUT).

Complete signal setups can be stored locally (9 internal non-volatile registers available) or on a memory card.

### Benchtop Testing

The HP 81101A features a graphic display showing all pulse parameters at a glance. The cursor keys and the modify knob allow fast and simple operation.

The user interface is designed to minimize the time invested in getting familiar with the instrument. After familiarization, the instrument supports quick setups of signals. This leaves you free to concentrate on the measurement task and testing of the DUT.



## **Automated Testing**

The HP 81101A features an HP-IB/SCPI-conform command structure for all features. Using this programming interface, the instrument can be easily integrated into all phases of test system development such as planning rack integration and test program generation.

Programs designed for the HP 81101A are compatible with all other models of the HP 81100 family.

### **NOTE**

For a command reference list, please refer to the *Reference Guide*, part number 81101-91011.

## The Front Panel

When used for benchtop testing, the instrument is mainly operated from the front panel.

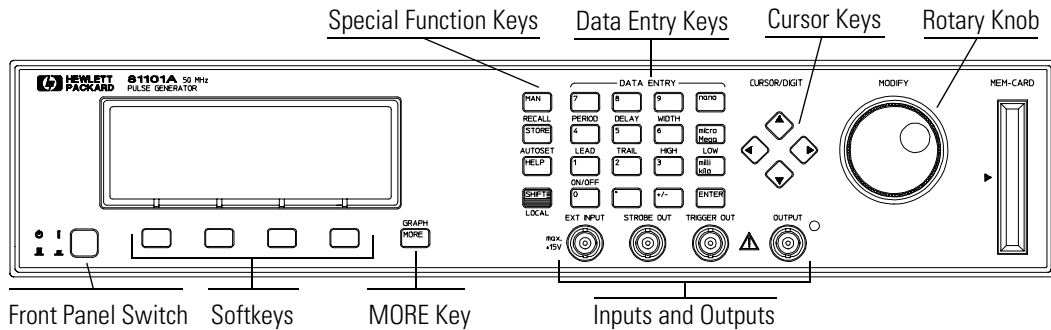

The **front panel switch** is used to switch on and off the instrument.

### NOTE

When the front panel switch is off, the instrument is in “standby” mode. The instrument is disconnected from the AC line power *only* by disconnecting the power cord.

The four keys below the display are the **softkeys** (software-controlled keys). The current function of each softkey is indicated in the corresponding box on the display.

Pressing the MORE key changes the softkey layout.

The other keys (**special function keys, data entry keys, cursor keys**) and the **rotary knob** are used to select and modify parameters when operating the instrument (see *“Operating the HP 81101A” on page 20*).

The major inputs and outputs of the instrument are available at the front panel:

- The external input (EXT INPUT) can be used to connect an external arming source (triggered or gated modes), or to perform pulse recovery (external width mode). For details, please refer to *“The Mode/Trigger Screen” on page 44*.
- The strobe output (STROBE OUT) provides a signal indicating the duration of a burst.  
In burst mode, the STROBE OUT signal marks the start and end of each burst of pulses generated. The rising edge of the STROBE signal is synchronized to the start of the first pulse period in a burst, the falling edge is synchronized to the start of the last pulse period in the burst. (see *“The Mode/Trigger Screen” on page 44*).  
You can set the output levels to TTL or ECL (see *“The Trigger-Level Screen” on page 65*)
- The trigger signal (TRIGGER OUT) marks the start of each pulse period (see *“The Mode/Trigger Screen” on page 44*). You can set the output levels to TTL or ECL (see *“The Trigger-Level Screen” on page 65*).
- The OUTPUT provides the signal output, the indicator shows the current state of the output (on or off).

**NOTE** An input connector for external frequency reference (CLOCK/REF INP.) is available at the rear panel (see *“The Rear Panel” on page 28*). When the rear panel option UN2 is ordered, all input and output connectors are available at the rear panel.

**NOTE** For information on the use of the memory card slot, refer to *“The Memory Card Screen” on page 67*.

## Operating the HP 81101A

This section guides you through the first steps when operating the HP 81101A via the user interface.

### **NOTE**

For information on operating the HP 81101A via remote control, please refer to the *Reference Guide*, part number 81101-91011.

## Switching On the Instrument



After switching on the instrument the display indicates that the instrument selftest is running. This can take several seconds to complete.

If the selftest fails, you see a flashing E at the bottom of the screen. Press the HELP key to see a list of the selftest error messages. Use the knob or the cursor keys to scroll through the list if necessary.

To return to normal operation press HELP again. Note that the selftest error messages are removed from the error queue after this.

## The Basic Screens

The major parameters for pulse generation can be set up in only two screens.

The **Mode/Trigger screen** allows you to set the fundamental operating and trigger modes with respect to the signal required.

CONTINUOUS	<b>PULSES</b>	<input checked="" type="radio"/> <b>MODIFY</b>	
	Single-Pulses at Out1		*PulseStrm
	Pulse-Period: internal Osc	Burst	
<b>MODE/TRG</b>	<b>OUTPUT</b>	<b>LIMITS</b>	<b>TRG-LEV</b>

*Press the MODE/  
TRG softkey to  
access this screen.*

In this screen, you can set up the signal to be triggered or continuous, and to be a pulse stream or a burst (several pulses followed by a pause) consisting of single or double pulses.

In the lower section you can specify the frequency source for the pulse period and the trigger source.

Introducing the HP 81101A Pulse Generator  
**Operating the HP 81101A**

The **Output** screen allows you to specify timing and level parameters for the signal to be generated.

Per 1.000 $\mu$ s Normal		OFF	1	<input type="radio"/> MODIFY			
Delay	0ps	Offset	+0.0mV	*OFF			
Width	100.0ns	Amplit	1.00V	ON			
LeadE	5.00ns	50 $\Omega$ into	50.0 $\Omega$				
Traie	=LeadE						
MODE/TRG		OUTPUT		LIMITS		TRG-LEV	

Press the **OUTPUT** softkey to access this screen.

In the left part of this screen, you can set up the timing for the signal (period, pulse width, transition times, ...). The right part is for the levels (normal or inverted signal, offset and amplitude, impedance, ...).

Furthermore, you can switch on and off the output.

Pressing **SHIFT + MORE (GRAPH)** when the Output screen is displayed, toggles between the textual display and a graphical representation of the parameters. Depending on the current cursor position (left or right part), the timing parameters or the level parameters are visualized.

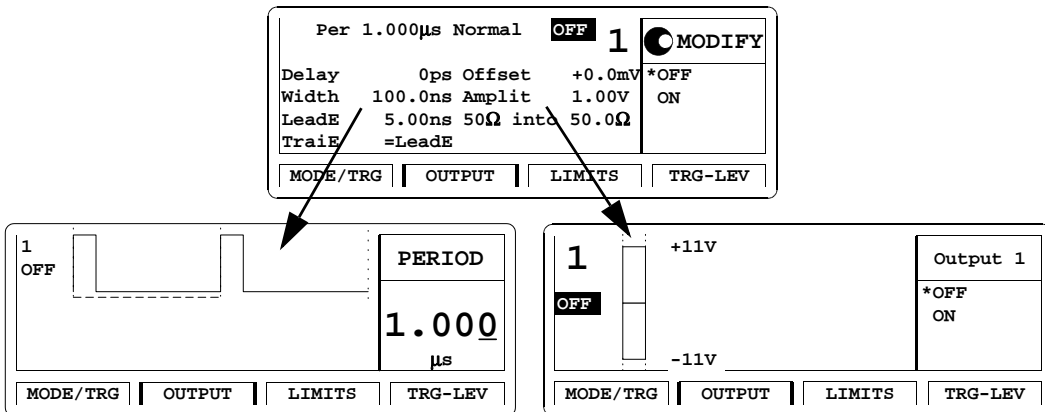

## Adjusting Parameters

Adjusting parameters within a screen, requires two steps:

- selecting the parameter
- adjusting its value

Some parameters allow different formats of their values. For example, the pulse width can be displayed and entered as an absolute value, as duty cycle (percentage of the period), or as the delay of the trailing edge.

The following sections show the standard procedure for adjusting parameters, and list some features useful for the advanced user.

### Standard Procedure

To experience the standard procedure for adjusting parameters, consider the following example where the duty cycle is set to 50%.

- 1 Press the OUTPUT softkey to access the Output screen.
- 2 Use the cursor keys to select the WIDTH parameter.

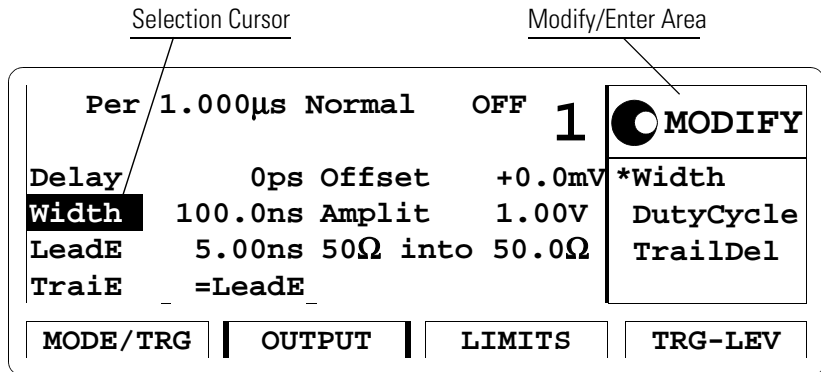

The available formats for the pulse width parameter are displayed in the Modify/Enter area.

## Operating the HP 81101A

*When changing the parameter format, the instrument automatically recalculates the value.*

- 3 Turn the knob to select DUTYCYCLE.  
The selected setting is indicated by an “\*”.
- 4 Move the cursor to the right to select the duty cycle value.
- 5 Use the data entry keys or the knob to enter the required value: 50.
- 6 Press the ENTER key to confirm your selection.

Per 1.000μs Normal		OFF	1	 MODIFY
Delay	0.0ps	Offset	+0.0mV	50.00 %
DtyCyc	50.00%	Amplit	1.00V	
LeadE	6.00ns	50Ω into	50.0Ω	
TraIE	=LeadE			
MODE/TRG	OUTPUT	LIMITS	TRG-LEV	

If you need to specify a unit for a parameter, simply press the appropriate unit key (NANO, MICRO/MEGA, MILLI/KILO) instead of the ENTER key.

With this small example, you have learned the basic steps required for adjusting parameters. For a complete reference of parameters and formats available in the individual screens, refer to [Chapter 3 “Using the HP 81101A” on page 43](#).



## Advanced Procedures

The following features can be used to make operation more comfortable.



- **Selecting parameters**

Most keys of the front panel have an additional function. The SHIFT key provides fast access to the additional functions of the data entry keys and the special function keys.

For example, it is possible to quickly access the pulse width parameter by pressing SHIFT + 0 (WIDTH). The entry focus will be positioned on the corresponding editing field.



- **Changing the step size**

When modifying a value in the Modify/Enter area, pressing the SHIFT key followed by cursor left/right moves the cursor to a different digit in the displayed number.

Thus, you can change the step size for parameter change before you vary the value either with the up/down cursor keys or the knob.

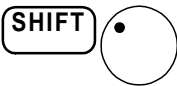

- **Overprogramming**

Pressing the SHIFT key while turning the knob, it is possible to exceed specified parameter ranges to utilize the instrument to its limits.

### NOTE

Proper operation of the instrument outside of the specified ranges is not guaranteed. It is recommended to have the output switched on when overprogramming to have the internal error check system activated. This error check system warns you about impossible settings.

## Switching the Output On and Off

When you switch the instrument on, the output is switched off to protect the device under test. The LED indicator next to the output connector indicates the output state.

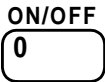

To switch the output on or off

- either press SHIFT + 0 (ON/OFF),
- or move the cursor to the ON/OFF parameter in the Output screen and select the appropriate value by turning the knob.

## Using the Special Function Keys

The instrument provides the following special function keys:



- The MAN key can be used in triggered or gated mode to manually trigger the instrument if there is no other source available (see *"The Mode/Trigger Screen" on page 44*).



- The STORE key can be used to store/recall to/from 1 to 9 individual settings in the instrument memory.  
In the internal memory location 0 there is a default setting stored. Pressing SHIFT + STORE (RECALL) and selecting 0 resets the instrument to the default setting.



- The SHIFT key provides fast access to additional functions.  
When the front panel controls are locked in remote control, pressing the SHIFT key unlocks the front panel controls.



- The HELP key provides access to the instrument's on-line help or in warning or error state, access to Warning/Error Report screen.  
Pressing SHIFT + HELP (AUTOSSET) sets the instrument to a valid setting based on the current period setting.

---

## Help is Available

Whenever you are in doubt or the instrument signals warnings or errors, press the HELP key.

### Help

If there are *no warnings or errors* pending, pressing the HELP key displays information on the currently selected parameter, the parameter help. More information is available within the help system:

- **Parameter Help**

The help information gives a short description of the parameter or setting options and the corresponding SCPI command(s) syntax for programming the parameter or setting.

If there is more than one screen available (indicated by small arrows), use the knob or the cursor keys to scroll through the help information.

To access parameter help from other screens of the help system, press the ON FIELD softkey.

- **Concept Help**

Pressing the CONCEPT softkey within the help system displays a short description of the instrument.

- **Serial Numbers and Software Revision**

Pressing the SERIAL # softkey within the help system displays information on serial numbers and software revision codes of the instrument.

### Warnings and Errors

If there are *warnings or errors* pending (indicated by a flushing W or E), pressing the HELP key displays a list of the current messages. Using the ERROR QU and WARNING softkeys, you can toggle between both lists. For more information on warnings and errors, see [“Warnings and Errors” on page 72](#).

### Exit Help

To exit from the help system, press the HELP key again, or press the EXIT HELP softkey.

## The Rear Panel

The rear panel always provides two connectors:

- The input connector for external frequency reference (CLOCK/REF INP.). This input can be used if a higher frequency accuracy is required, or if you need frequency locking.
- The HP-IB connector providing the interface for remote control.

The following figure shows the rear panel view with the option UN2.

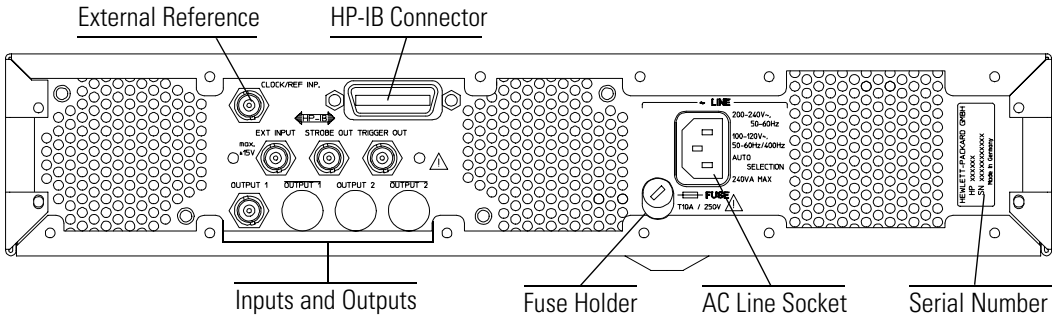

With option UN2 the major inputs and outputs of the instrument (as described in *“The Front Panel” on page 18*) are available at the rear panel:

- external input (EXT INPUT)
- strobe output (STROBE OUT)
- trigger signal (TRIGGER OUT)
- signal output (OUTPUT)

---

# 2 Getting Started

---

The intention of this chapter is to give the necessary steps to set up generic signals for first-time users of the HP 81101A.

This chapter provides examples for the following types of signals:

- *“Setting Up a Clock Signal” on page 30*
- *“Setting Up a Pulse Signal” on page 35*
- *“Setting Up a Burst Signal” on page 39*

At the end of each example, the required set of device commands is listed to provide programming examples. For further information on the commands and a complete command reference please refer to the *Reference Guide*, p/n 81101-91011.

The examples are intended to be performed one after the other. Therefore, the first example provides the most detailed instructions, while the other examples are described on a higher level.

## Setting Up a Clock Signal

### Task

Set up a continuous clock signal with 25 MHz frequency with PLL accuracy, a duty cycle of 50 %, 6 ns transition times, a high level of 2.5 V and low level of 0 V.

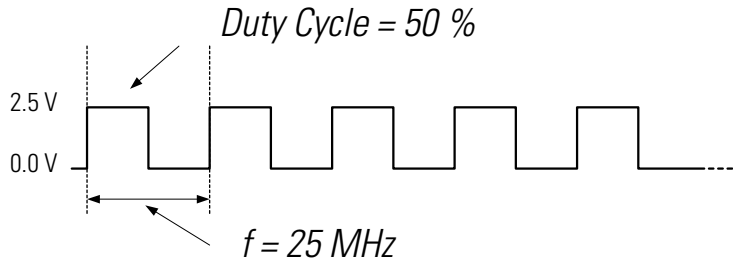

### Instructions

To set the **operating mode and trigger mode** as required:

- 1 Reset all parameters and modes by pressing SHIFT + STORE (RECALL) + 0.
- 2 Press the MODE/TRG softkey to enter the Mode/Trigger screen. Trigger mode CONTINUOUS and operating mode PULSES are selected by default.
- 3 Move the entry focus down to PULSE-PERIOD and turn the knob to select INTERNAL PLL.

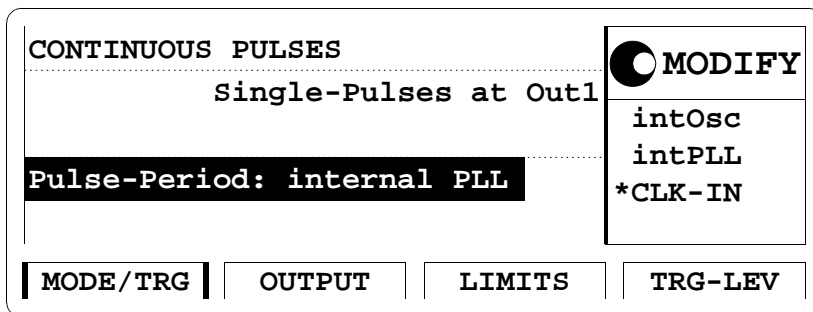

To set the **timing parameters** as required:

- 1 Press the OUTPUT softkey to enter the Output screen.
- 2 Press SHIFT + 0 (ON/OFF).  
 This turns on the Output and activates the internal error check to detect parameter conflicts.
- 3 Move the entry focus to PER and turn the knob to select FREQ.
- 4 Move the entry focus to the right (to the frequency entry field) and enter a value of 25 MHz by pressing 2 + 5 + MICRO/MEGA.  
 A warning is displayed, indicating a potential conflict in your settings. You can ignore this, because the conflict will be solved in the next steps.
- 5 Move the entry focus down to WIDTH and select DUTYCYCLE.
- 6 Move the entry focus to the right and enter 50 % by typing 5 + 0 + ENTER.
- 7 Move the entry focus down to the leading edge entry field and press 6 + NANO.  
 The trailing edge is set to be the same as the leading edge (TRAIE = LEADE) by default.

Freq 25.00MHz Normal ON 1	<input checked="" type="radio"/> MODIFY
Delay 0.0ps Offset +0.0mV DtyCyc 50.00% Amplit 1.00V LeadE <b>6.00ns</b> 50Ω into 50.0Ω TraiE =LeadE	6.00 ns
MODE/TRG   OUTPUT   LIMITS   TRG-LEV	

- 8 Press SHIFT + MORE (GRAPH) to see a preview of your signal.

Getting Started  
**Setting Up a Clock Signal**

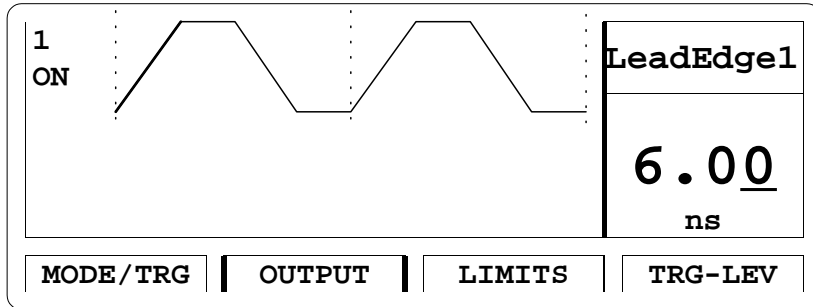

You can modify the parameter displayed in the Modify/Enter area, and immediately check how your changes affect the signal. Use the cursor keys to switch to another parameter.

- 9 Press SHIFT + MORE (GRAPH) to return to the textual screen.

To set the **level parameters** as required:

- 1 Move the entry focus to OFFSET/AMPLITUDE and turn the knob to select HIGH-LOW.
- 2 Move the entry focus to the high level entry field, enter 2.5 and press the ENTER key.

In the same way, enter 0 for the low level. The impedance is 50Ω source into 50Ω load by default.

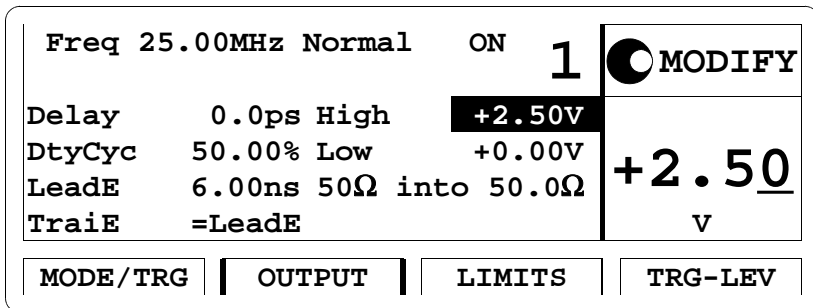

**NOTE**

There is also a graphical screen available for the level parameters.



Here is the signal as displayed on an HP 54810A Infinium oscilloscope. Use the generator's TRIGGER OUT to trigger the scope.

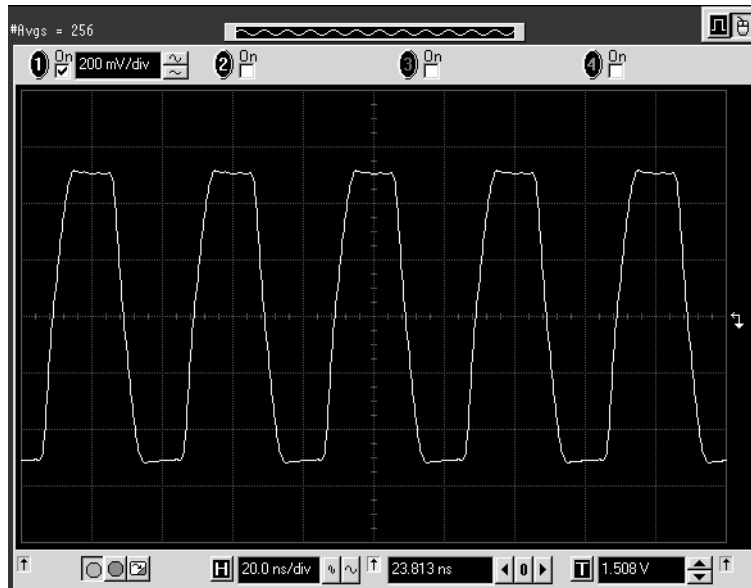

## Getting Started

### Setting Up a Clock Signal

#### Programming Example

If you want to include this clock signal in your HP-IB program, use the following command lines. The comment lines starting with a # are not required.

```
# Reset the instrument to start from a defined, default status.
*RST

# Switch off the automatic display update to increase programming
# speed.
:DISPlay OFF

# Internal PLL has to be set as period source.
:ARM:SOURce INT2

# Set the frequency to 25 MHz, the duty cycle to 50 % and the
# leading and trailing edge to 6 ns.
:FREQuency 25 MHZ
:PULSe:DCYCLE 50
:PULSe:TRANSition 6NS

# Set the high level to 2.5 Volts, the low level to 0.0 Volts.
:VOLTage:HIGH 2.5V
:VOLTage:LOW 0V

# Enable the output.
:OUTPut ON
```

## Setting Up a Pulse Signal

### Task

Set up a continuous pulse signal with 50 ns period, a pulse width of 30 ns, a leading edge of 6 ns, a trailing edge of 10 ns, an amplitude of 3.3 V and an offset of 1.65 V (high level 3.3 V, low level 0.0 V).

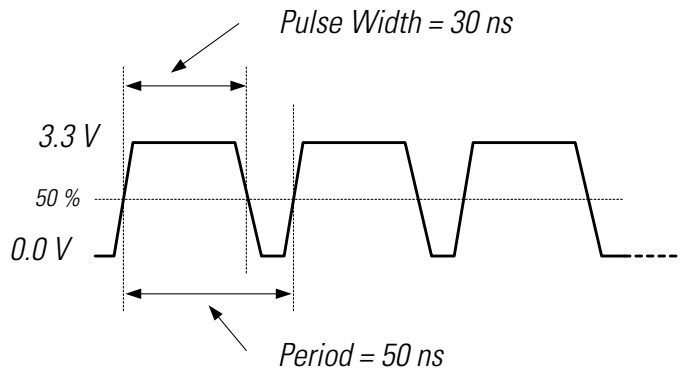

### Instructions

To set the **operating mode and trigger mode** as required:

- 1 Reset all parameters and modes by pressing SHIFT + STORE + 0.
- 2 Press the MODE/TRG softkey to enter the Mode/Trigger screen.  
The default settings can be used for this example. For reference the Mode/Trigger screen is displayed. There is nothing to change.

CONTINUOUS	<b>PULSES</b>	<input type="radio"/> MODIFY
Single-Pulses at Out1		*PulseStrm
Pulse-Period: internal Osc		Burst
MODE/TRG	OUTPUT	LIMITS
TRG-LEV		

Getting Started  
**Setting Up a Pulse Signal**

To set the **timing parameters** as required:

- 1 Press the OUTPUT softkey to enter the Output screen.
- 2 Switch on the output.
- 3 Enter a period of 50 NS.  
A warning is shown, which you may ignore, because the parameter conflict will be solved in the next steps.
- 4 Enter a pulse width of 30 NS.
- 5 Enter 6 NS for the leading edge.
- 6 For the trailing edge, select ABSOLUTE and enter a value of 10 NS.

Per 50.00ns Normal ON 1				<input checked="" type="radio"/> MODIFY
Delay	0.0ps	Offset	+0.0mV	10.0 ns
Width	30.00ns	Amplit	1.00V	
LeadE	6.00ns	50Ω into	50.0Ω	
TraiE	10.0ns			
MODE/TRG	OUTPUT	LIMITS	TRG-LEV	

To set the **level parameters** as required:

- 1 Enter an offset of 1.65 V.
- 2 Enter an amplitude of 3.30 V.

Per 50.00ns Normal ON 1				<input checked="" type="radio"/> MODIFY
Delay	0.0ps	Offset	+1.65V	3.30 V
Width	30.00ns	Amplit	3.30V	
LeadE	6.00ns	50Ω into	50.0Ω	
TraiE	10.0ns			
MODE/TRG	OUTPUT	LIMITS	TRG-LEV	

Here is the figure as displayed on the HP 54810A Infinium oscilloscope. Use the generator's TRIGGER OUT to trigger the scope.

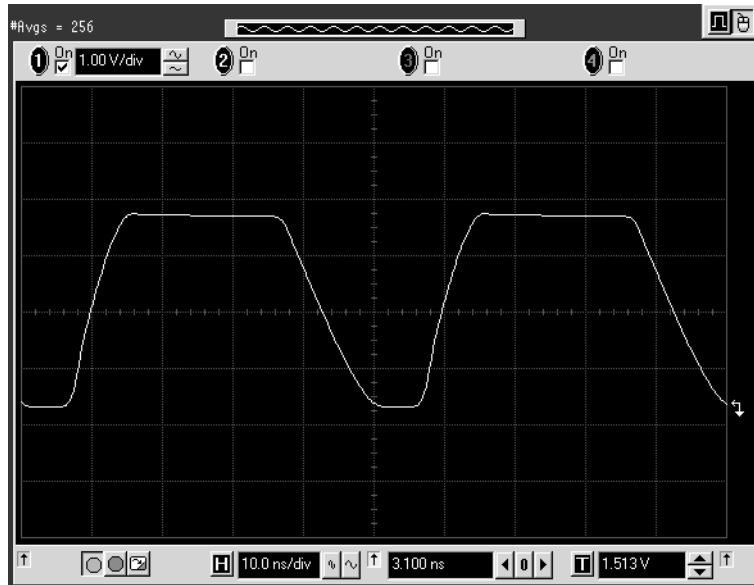

## Getting Started

### Setting Up a Pulse Signal

#### Programming Example

If you want to include this pulse signal in your HP-IB program, use the following command lines. The comment lines starting with a # are not required.

```
# Reset the instrument to start from a defined, default status.
*RST

# Switch off the automatic display update to increase programming
# speed.
:DISPlay OFF

# Pulse stream operating mode is required, but as we start
# from a default status it is not necessary to send a command for
# setting the instrument into pulse stream operating mode.
# Set the period to 50 ns, the pulse width to 20 ns, the leading
# edge to 6 ns and the trailing edge to 10 ns.
:PULSe:PERiod 50NS
:PULSe:WIDTh 30NS
:PULSe:TRANSition 6NS
:PULSe:TRANSition:TRAILing:AUTO OFF
:PULSe:TRANSition:TRAILing 10NS

# Set the amplitude to 3.3 Volts, the offset to 1.65 Volts.
:VOLTage 3.3V
:VOLTage:OFFSet 1.65V

# Enable the output
:OUTPut ON
```

## Setting Up a Burst Signal

### Task

Set up a burst signal with a burst repetition of  $2\ \mu\text{s}$ . Each burst consists of two double-pulses at a period of  $500\ \text{ns}$ . The pulse width is  $100\ \text{ns}$ , the delay between the two pulses of a double-pulse is  $200\ \text{ns}$ . The levels are  $2\ \text{Vpp}$  amplitude and  $0\ \text{V}$  offset.

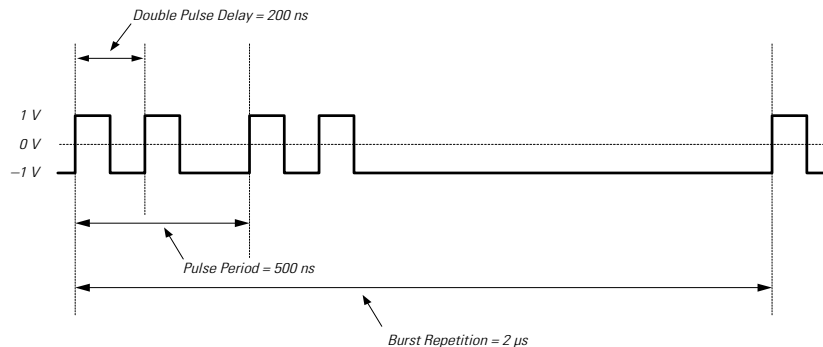

### Instructions

To set the **operating mode and trigger mode** as required:

- 1 Reset all parameters and modes by pressing **SHIFT + STORE + 0**.
- 2 Press the **MODE/TRG** softkey to enter the Mode/Trigger screen.  
The internal PLL is used to trigger the startable internal oscillator. The PLL defines the burst repetition, the oscillator generates the pulse period. This requires the following settings:
- 3 Move to **CONTINUOUS** and turn the knob to select **TRIGGERED**.
- 4 Move to **PULSES** and select **BURST**.
- 5 Move down and select **DOUBLE (DOUBLE-PULSES AT OUT 1)**.
- 6 Move left and select a burst length of **2**.
- 7 Move down and select **TRG'D BY: PLL** and set the period to **2.000  $\mu\text{s}$**  (burst repetition).

Getting Started  
**Setting Up a Burst Signal**

TRIGGERED BURSTS OF		<input type="radio"/> MODIFY	
2-Double-Pulses at Out1			
Pulse-Period: internal Osc		2.000 μs	
Trg'd by: PLL -> Per 2.000 μs			
MODE/TRG	OUTPUT	LIMITS	TRG-LEV

To set the **timing parameters** as required:

- 1 Press the OUTPUT softkey to enter the Output menu.
- 2 Switch on the Output.
- 3 Enter a pulse period of 500 NS.
- 4 Enter a double-pulse delay (DBLDEL) of 200 NS.

To set the **level parameters** as required:

- 1 Enter an amplitude of 2.00 V.

Per 500.0ns Normal		ON	1	<input type="radio"/> MODIFY
Dbldel	200.0ns	Offset	+0.0mV	
Width	100.0ns	Amplit	2.00V	2.00 V
LeadE	5.00ns	50Ω into	50.0Ω	
Traie	=LeadE			
MODE/TRG	OUTPUT	LIMITS	TRG-LEV	



The following figure shows the signals as displayed on the HP 54810A Infinium Oscilloscope if you connect OUTPUT to channel 1, STROBE OUT to channel 2, and use the generator's TRIGGER OUT to trigger the scope.

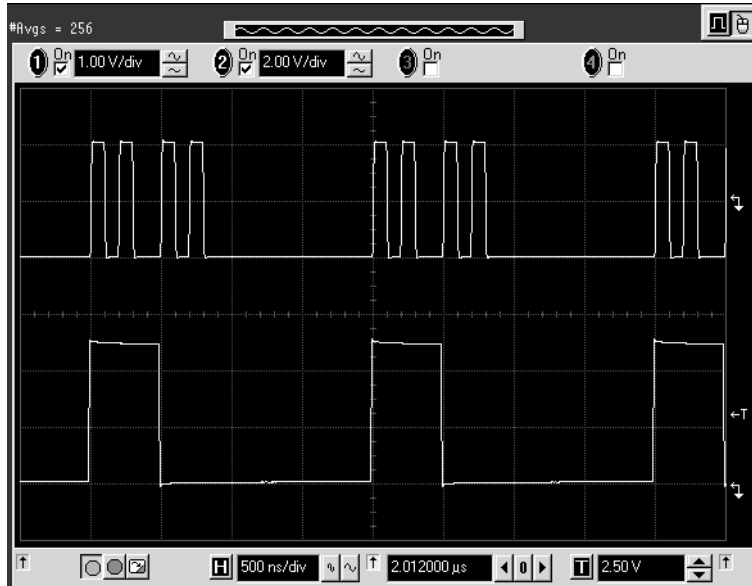

## Getting Started

### Setting Up a Burst Signal

#### Programming example

If you want to include this burst signal in your HP-IB program use the following command lines. The comment lines starting with a # are not required.

```
# Reset the instrument to start from a defined, default status.
*RST

# Switch off the automatic display update to increase programming
# speed.
:DISPlay OFF

# Set the instrument to burst mode by selecting a burst count
# of 2. Choose double pulses. Select triggered mode by selecting
# PLL as the trigger source and set the burst repetition to 2  $\mu$ s.
:TRIGger:COUnT 2 # Set Burst mode with burst count of 2
:ARM:SOURce INT2 # Set Triggered mode with PLL as
# trigger source
:ARM:PERiod 2US # Set burst repetition of 2  $\mu$ s
:PULSe:DOUble ON # second channel generates double pulses
# per period

# Set the double pulse delay to 200 ns and the width to 100 ns.
:PULSe:PERiod 500NS
:PULSe:WIDTh 100NS
:PULSe:DOUble:DELAy 200NS

# Set the output amplitude to 2 Volts and the offset to
# 0.0 Volts.
:VOLTage 2V

# Enable the output.
:OUTPut ON
```

---

# 3

---

## Using the HP 81101A

This chapter provides complete reference information for using the HP 81101A by means of the user interface screens.

Each screen is described in detail. To access the individual screens, use the softkeys below the screen. There are two softkey layouts:

- the default layout



- the alternative layout displayed after pressing the MORE key



At the end of this chapter, *“Warnings and Errors” on page 72* provides details on the instrument’s warning and error messaging system.

**NOTE**

For general information on using the HP 81101A and information on the instrument’s hardkeys, please refer to *Chapter 1 “Introducing the HP 81101A Pulse Generator” on page 15*.

**NOTE**

For information on using the HP 81101A via remote control, please refer to the *Reference Guide*, part number 81101-91011.

## The Mode/Trigger Screen

This section describes the Mode/Trigger screen, starting with an overview of the available parameter combinations, followed by detailed descriptions of each combination.

### Overview

To access the Mode/Trigger screen, press the MODE/TRG softkey.

The following figure shows a typical Mode/Trigger screen, where the individual parameters are indicated. The parameter combinations are listed in the table on the next page.

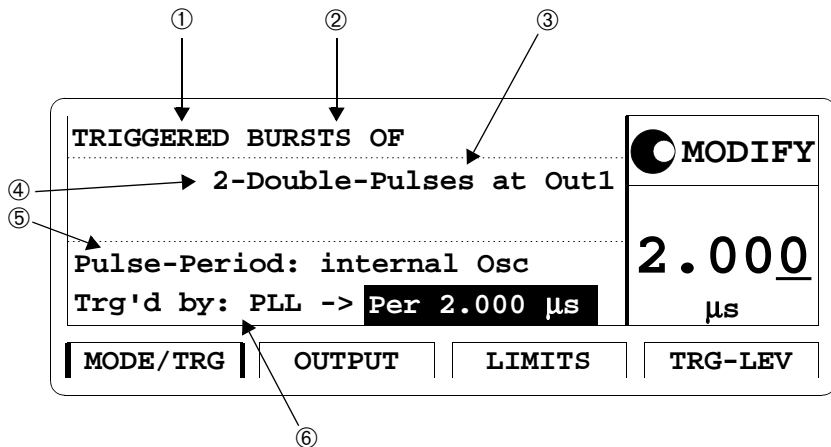

In this screen, you can set up the signal to be triggered or continuous, and to be a pulse stream or a burst (several pulses followed by a pause) consisting of single or double pulses.

Furthermore, you can specify the pulse and trigger sources.

The following table provides a list of possible parameter combinations. The rows refer to the numbers in the figure.

① <b>Trigger Mode</b>	<b>Continuous</b>		<b>Triggered</b>		<b>Gated</b>		<b>Ext. Width</b>
② <b>Pulse Mode</b>	<b>Pulses</b>	<b>Burst</b>	<b>Pulses</b>	<b>Burst</b>	<b>Pulses</b>	<b>Burst</b>	
③ <b>Pulse Type</b>	Single/Double		Single/Double		Single/Double		
④ <b>Length</b>		2-65536		2-65536		2-65536	
⑤ <b>Period Source</b>	internal Osc. internal PLL CLK-IN			internal Osc. internal PLL CLK-IN	internal Osc. internal PLL CLK-IN		
⑥ <b>Arming Source</b>			MAN key Ext. Input	MAN key Ext. Input PLL	MAN key Ext. Input		MAN key Ext. Input
<b>Trigger Out</b>	marks each pulse period generated						
<b>Strobe Out</b>	not used	↑ on 1st ↓ on last	not used	↑ on 1st ↓ on last	not used	↑ on 1st ↓ on last	not used

The pulse period source can be selected from internal oscillator, internal PLL, and external CLK-IN:

- If you have to trigger after an external event, use the startable oscillator (**internal Osc.**), which starts on the external signal with a fixed latency.
- If you do not have to trigger but need a high accuracy frequency, then use the **internal PLL** clock generation circuitry.
- For even more accuracy, you can use the external CLK-IN.

In triggered/gated mode the internal PLL can be used as an arming source. However, the internal PLL cannot be used as pulse and arming source at the same time.

The following sections explain the individual mode combinations in more detail. For each combination of trigger mode and pulse mode, typical timing diagrams are provided, showing single and double pulses.

## Continuous Pulses Mode

The following figure shows typical timings for trigger mode CONTINUOUS and pulse mode PULSES.

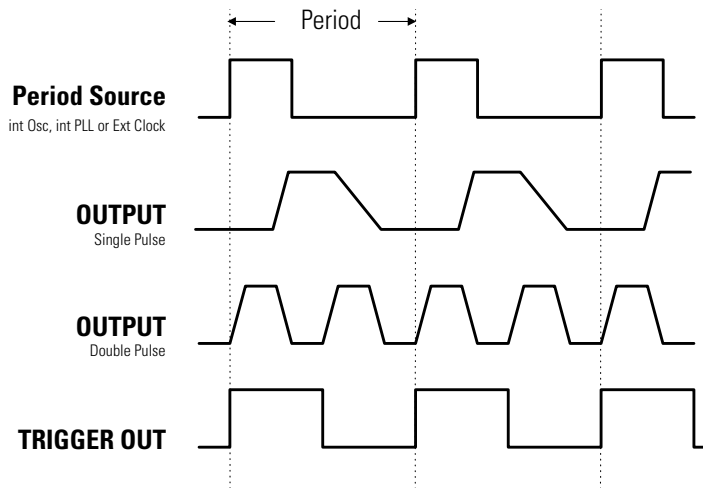

### Characteristics

- Pulse periods are generated continuously.
- You can select single pulses or double pulses per pulse period.
- For the pulse period source you can select from
  - internal Osc (VFO)
  - internal PLL (higher accuracy)
  - external CLK-IN (external signal), synchronize to rising or falling edge
- TRIGGER OUT marks each pulse period.

### NOTE

STROBE OUT is not used in continuous pulse mode.

## Continuous Burst Mode

The following figure shows typical timings for trigger mode CONTINUOUS and pulse mode BURST.

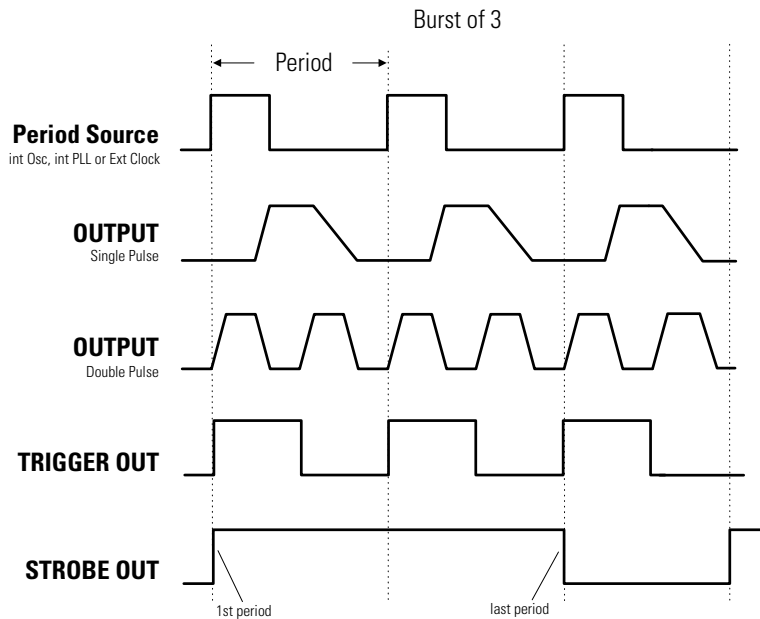

### Characteristics

- A burst of pulse periods is repeated continuously.
- You can select the number of pulse periods per burst in the range of 2–65536.
- You can select single pulses or double pulses per pulse period.
- For the pulse period source you can select from
  - internal Osc (VFO)
  - internal PLL (higher accuracy)
  - external CLK-IN, synchronize to rising or falling edge.
- TRIGGER OUT marks each pulse period.
- STROBE OUT rises at the start of the first pulse period in a burst, and falls at the start of the last pulse period.

## Triggered Pulses Mode

The following figure shows typical timings for trigger mode TRIGGERED and pulse mode PULSES. The pulses are triggered by the rising edge of the arming source.

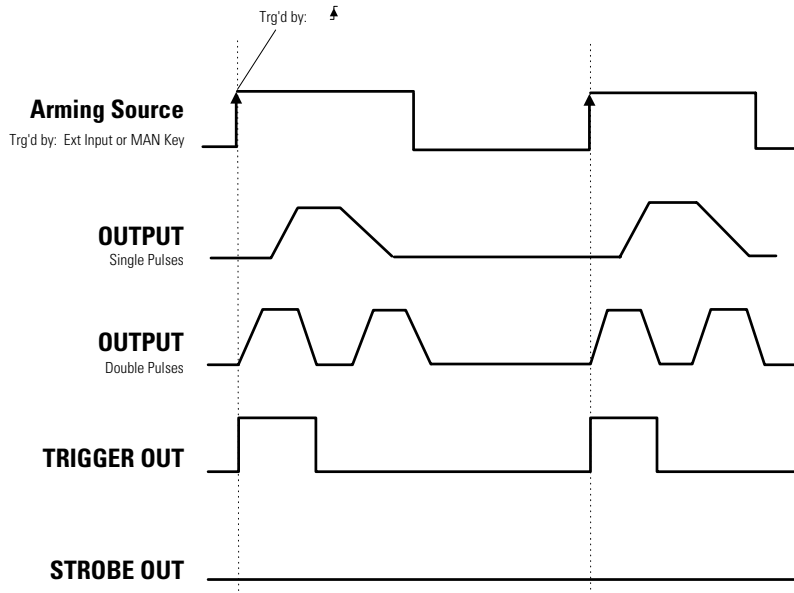

### Characteristics

- Single pulse periods are triggered by (TRG'D BY) an active edge at the selected arming source:
  - MAN key on front panel, triggered by press or release or both.
  - EXT INPUT triggered by rising or falling or both edges.
- You can select single pulses or double pulses per pulse period.
- TRIGGER OUT marks each pulse period.
- STROBE OUT is not used in triggered pulse mode.

### NOTE

The PLL *cannot* be selected as the arming source. Select continuous pulse mode with the PLL as period source to achieve the same result.



In contrast to the previous figure, this figure shows a timing diagram where the pulses are triggered by both rising and falling edges of the arming source.

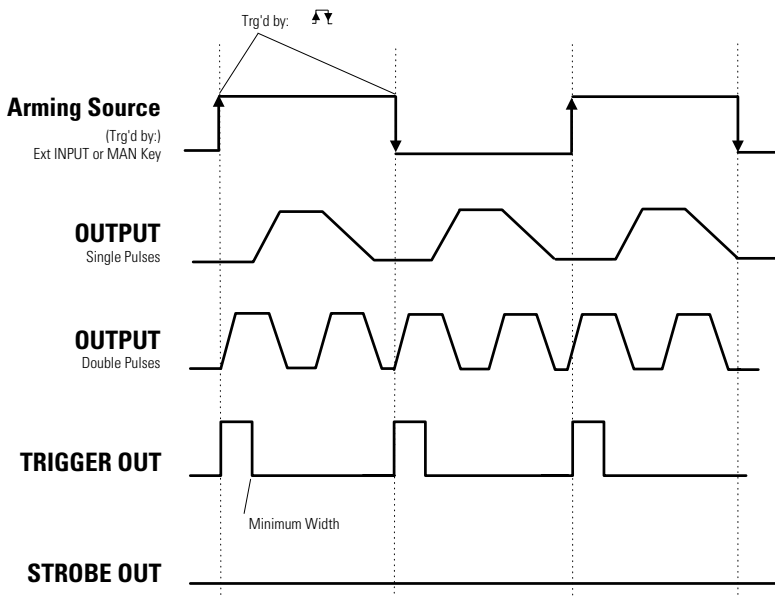

## Triggered Burst Mode

The following figures show typical timings for trigger mode TRIGGERED and pulse mode BURST. The bursts are triggered by the rising edge of the arming source.

For the first example, the *synchronously triggerable* internal oscillator is used to source the period.

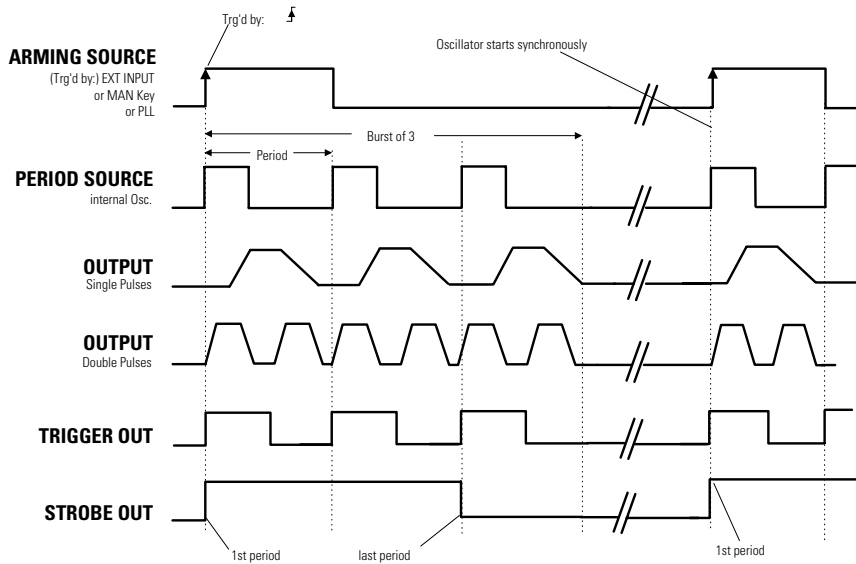

### Characteristics

- A burst of pulse periods is triggered by an active edge at the selected arming source
  - MAN key on front panel, triggered by press or release or both.
  - EXT INPUT triggered by rising or falling or both edges.
  - PLL (internally triggered bursts)

When using the internal PLL as the arming source, you must specify the triggering period.

- You can select the number of pulse periods per burst in the range of 2–65536.
- You can select single pulses or double pulses per pulse period.

- TRIGGER OUT marks each pulse period.
- STROBE OUT rises at the start of the first pulse period in a burst and falls at the start of the last pulse period.

For the second example, either the internal PLL or an external CLK-IN are used to source the period—both cannot be triggered synchronously.

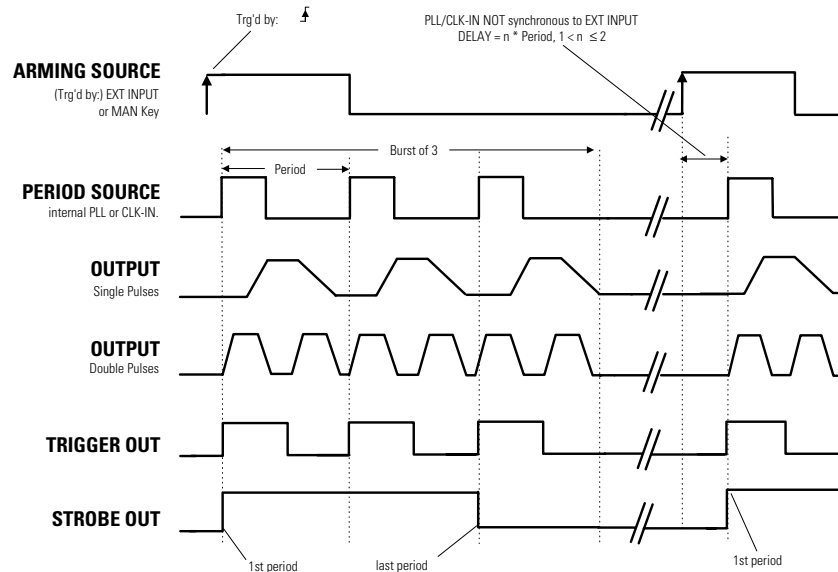

**NOTE**

You cannot use the PLL as both pulse period source and arming (TRG'D BY) source at the same time.

## Gated Pulses Mode

The following figures show typical timings for trigger mode GATED and pulse mode PULSES.

For the first example, the *synchronously triggerable* internal oscillator is used to source the period.

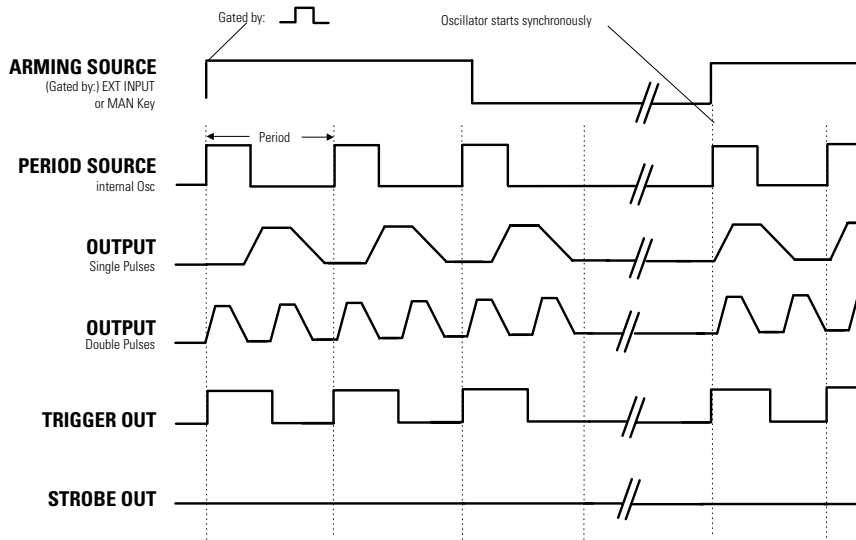

### Characteristics

- Pulse periods are gated by (enabled by) an active level at the selected arming source:
  - MAN key on the front panel, gated while pressed or released or both.
  - EXT INPUT (external signal) gated by high, low or both levels.
- You can select single pulses or double pulses per pulse period.
- TRIGGER OUT marks each pulse period.
- STROBE OUT is not used in gated pulses mode.

For the second example, either the internal PLL or an external CLK-IN are used to source the period—both cannot be triggered synchronously.

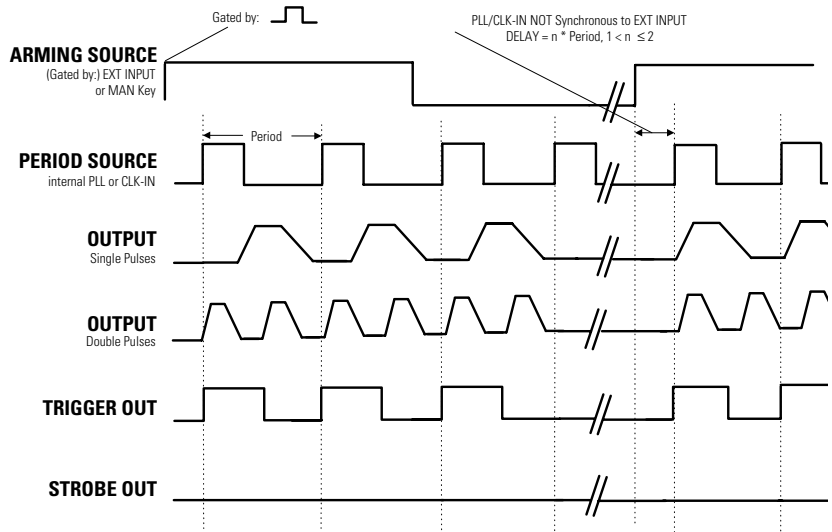

## Gated Burst Mode

The following figures show typical timings for trigger mode GATED and pulse mode BURST.

For the first example, the *synchronously triggerable* internal oscillator is used to source the period.

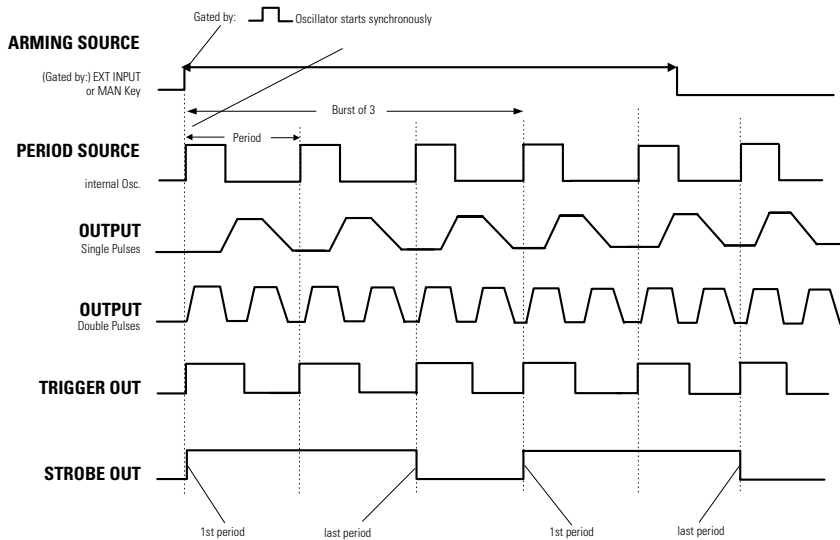

### Characteristics

- Bursts of pulse periods are gated by (enabled by) an active level at the selected arming source:
  - MAN key on the front panel, gated while pressed or released or both.
  - EXT INPUT (external signal) gated by high, low or both levels.
- You can select single pulses or double pulses per pulse period.
- TRIGGER OUT marks each pulse period.
- STROBE OUT rises at the start of the first pulse period in a burst and falls at the start of the last pulse period.

For the second example, either the internal PLL or an external CLK-IN are used to source the period—both cannot be triggered synchronously.

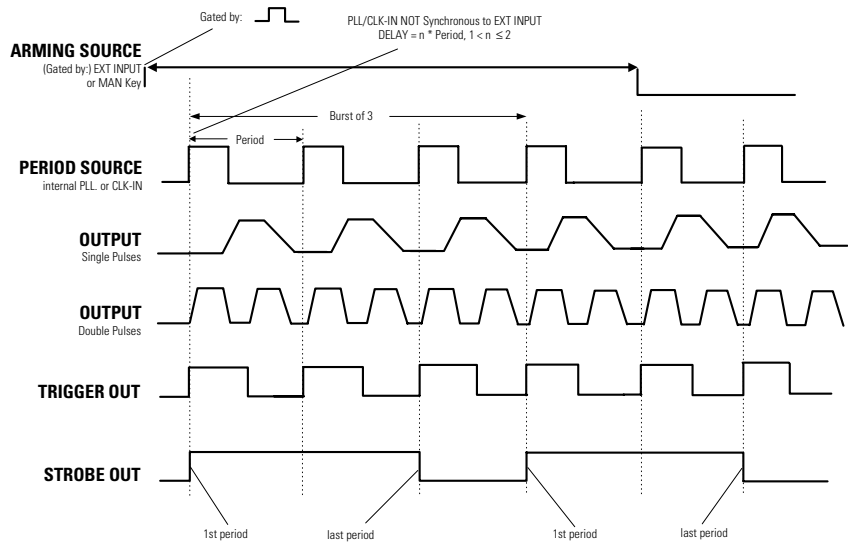

## External Width Mode

In external width mode, the pulse width is determined by an external signal. You can choose between:

- **MANKEY:** Pressing the key generates a leading edge, releasing the key generates a trailing edge.
- **EXT-IN:** A rising edge at the EXT INPUT generates a leading edge, a falling edge generates a trailing edge.

The threshold and impedance of the EXT INPUT can be set on the Trigger Level screen.

The period, delay, and width of the output pulse are not programmable in this mode, because they are determined by the external signal.

The TRIGGER OUT rises and falls parallel to the OUTPUT signal.

## The Output Screen

The Output screen shows both timing and level parameters on one screen.

To access the Output screen, press the OUTPUT softkey.

### Timing Parameters

You can use the left part of the Output screen to view and control the pulse timing parameters.

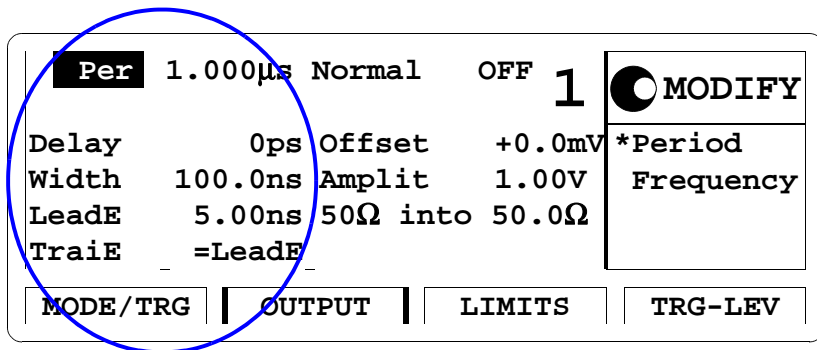

<b>Per</b>	1.000 $\mu$ s	Normal	OFF	1	 <b>MODIFY</b>
Delay	Ops	Offset	+0.0mV	*Period	
Width	100.0ns	Amplit	1.00V	Frequency	
LeadE	5.00ns	50 $\Omega$ into	50.0 $\Omega$		
TraIE	=LeadE				
<b>MODE/TRG</b>	<b>OUTPUT</b>	<b>LIMITS</b>	<b>TRG-LEV</b>		

The individual timing parameters are described in more detail in the following. All parameters can be entered in different formats.

#### NOTE

With the HP 81101A you can vary timing parameters without the risk of glitches or drop outs, which could cause measurement errors. This applies to continuous mode with timing values < 100 ms (frequency < 10 Hz), and consecutive values between one-half and twice the previous value.



When you press SHIFT + MORE (GRAPH) while one of the timing parameters is selected, you will see a graphical representation of the timing parameters. The currently selected parameter is displayed in the Modify/Enter area and is indicated by dashed or bold lines in the graphical display.

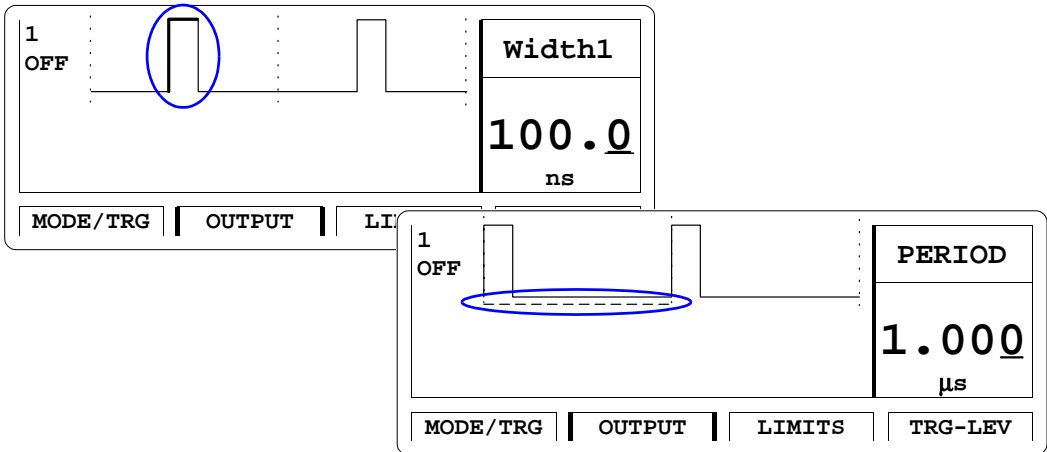

Use the left/right cursor keys to toggle between the individual timing parameters.

**NOTE**

Note that in graphics mode you can only adjust the *values* of each parameter, not the parameter format. If you want to change the format of a parameter, for example WIDTH to DTYCYC, you must be in text mode to select the parameter name with the cursor.

**Pulse Period Parameter**

Set the pulse period as either PERIOD or FREQUENCY.

If you select the CLK-IN as the pulse period source on the Mode/Trigger screen, the pulse period/frequency is determined from the signal applied to the CLOCK/REF INP. connector:

- MEAS ONCE

The external signal is measured only once. Press ENTER to measure again.

- **MEAS CONT**  
The external signal is continuously measured until the instrument receives a command via HP-IB.  
To invoke continuous measurements again, you have to bring the instrument in local operating mode by pressing SHIFT (LOCAL) and start continuous measurement again.

## **Pulse Delay Parameter**

Delay the leading edge of the pulse within the pulse period. There are three delay formats available:

- **DELAY** or **DBLDEL** (select **ABSOLUTE**)  
DELAY is the absolute delay from the start of a pulse period to the start of the leading edge of the pulse.  
If double pulses are selected on the Mode/Trigger screen, the DBLDEL parameter specifies the delay between the first and second pulse in each pulse period.  
The absolute delay is independent of the pulse period. So the leading edge does not move relative to the start of the period if you change the period.
- **DELAY%** (select **% OF PERIOD**)  
The delay from the start of the pulse period to the start of the leading edge expressed as a percentage of the pulse period. In this format, if you change the period, the leading edge moves relative to the start of the period in order to maintain the percentage delay.
- **PHASE** (select **PHASE**)  
The phase delay in degrees from the start of the pulse period to the start of the leading edge ( $360^\circ = 1$  pulse period). In this format, if you change the period, the leading edge moves relative to the start of the period in order to maintain the phase delay.

## Pulse Width Parameter

Set the width of the output pulse. There are three width formats available:

- **WIDTH** (select WIDTH)  
The absolute pulse width measured from the start of the leading edge to the start of the trailing edge. In this format, the pulse width is independent of changes in pulse period and delay.
- **DTYCYC** (select DUTYCYCLE)  
The duty cycle is the pulse width measured from the start of the leading edge to the start of the trailing edge expressed as a percentage of the period. In this format, if you adjust the period, the absolute width is adjusted to maintain the duty cycle.
- **TRADEL** (select TRAILDEL)  
The trailing delay is the absolute delay from the start of the pulse-period to the start of the trailing edge. In this format the trailing edge remains fixed relative to the start of the pulse period if you adjust the pulse delay (leading edge delay) or the pulse period.

### **NOTE**

You cannot have the width format set to DTYCYC and the leading/trailing-edge format set to percentage of width (LEADED%/TRAILE%) at the same time.

## Leading Edge Parameter

Set the leading edge transition time of the pulse, measured from 10% to 90% of the pulse amplitude. There are two formats available:

- **LEADE** (select ABSOLUTE)  
The absolute transition time measured from 10% to 90% of the pulse amplitude. In this format the leading edge is independent of the pulse width.
- **LEADE%** (select % OF WID)  
The absolute transition time expressed as a percentage of the pulse width. In this format, if you adjust the pulse width, the transition time is adjusted to maintain the edge time as a percentage of the width.

**NOTE** The leading and trailing edges are independently programmable within certain ranges only, see “*Transition Times*” in the *Reference Guide*.

**NOTE** You cannot have the width format set to DTYCYC and the leading/trailing-edge format set to percentage of width (LEADE%/TRAIE%) at the same time.

### **Pulse Trailing Edge Parameter**

Set the trailing edge transition-time of the pulse, measured from 10% to 90% of the pulse amplitude. There are three formats available:

- =LEADE (select =LEADE)  
The trailing edge transition time is coupled directly to the leading edge to maintain a symmetrical pulse.
- TRAIE (select ABSOLUTE)  
The absolute transition time measured from 90% to 10% of the pulse amplitude. In this format the trailing edge is independent of the leading edge and the pulse width.
- TRAIE% (select % OF WID)  
The trailing edge transition time expressed as a percentage of the pulse width. In this format, if you adjust the pulse width, the transition time is adjusted to maintain the edge time as a percentage of the width.

**NOTE** The leading and trailing edges are independently programmable within certain ranges only, see “*Transition Times*” in the *Reference Guide*.

**NOTE** You cannot have the width format set to DTYCYC and the leading/trailing edge format set to percentage of width (LEADE%/TRAIE%) at the same time.

## Level Parameters

You can use the right part of the Output screen to view and control the pulse level parameters and to enable or disable the outputs.

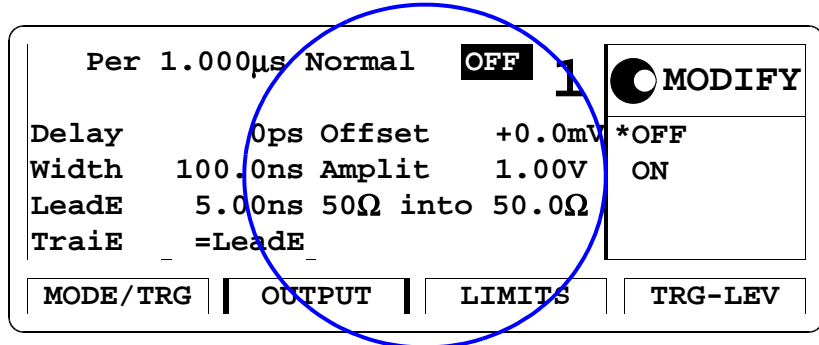

The individual level parameters are described in more detail in the following. All parameters can be entered in different formats.

When you press SHIFT + MORE (GRAPH) while one of the level parameters is selected, you will see a graphical representation of the level parameters. The currently selected parameter is displayed in the Modify/Enter area and is indicated in the graphical display.

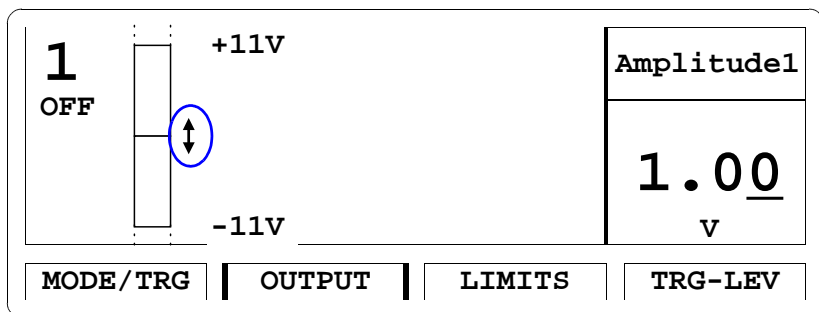

When output limits are on, the limits are indicated on the Output screen in graphics mode (see *"The Limits Screen" on page 64*).

**NOTE** Note that in graphics mode you can only adjust the *values* of each parameter, not the parameter format. If you want to change the format of a parameter, for example OFFS-AMPL to HIGH-LOW, you must be in text mode to select the parameter name with the cursor.

**NOTE** When the output is switched on, the instrument monitors the actual voltage and current levels at the output. The output is automatically switched off if voltage levels or power dissipation reach levels which could damage the output circuits.

### **Normal/Complement Parameter**

Switch the output between normal and complement mode:

- NORMAL  
Pulse leading edge rises from low to high level, trailing edge falls from high to low level.
- COMPLMNT  
Pulse leading edge falls from high to low level, trailing edge rises from low to high level.

**NOTE** This parameter is only available in text mode.

### **Offset/Amplitude, High/Low Level Parameters**

Set and display the pulse levels in terms of either offset and amplitude, or high and low level. You can quickly set TTL or ECL output levels using the SET TTL and SET ECL formats.

- SET TTL  
Select high and low level formats and automatically set the levels to the default TTL levels:  
TTL-HI: +2.50 V  
TTL-LOW: +0.0 mV  
The default levels are set once and can be adjusted afterwards by moving the entry focus to the values as normal.
- HIGH-LOW  
Select high and low level format for the pulse levels.

- **OFFS-AMPL**

Select offset and amplitude format for the pulse levels. Offset is measured from 0V to the middle of the pulse amplitude. Pulse amplitude is the difference between the high and low levels of the pulse.

- **SET ECL**

Select high and low level format and automatically set the levels to the default ECL levels:

ECL-HI:     -850 mV

ECL-LOW:   -1.80 V

These default levels are set once and can be adjusted afterwards by moving the entry focus to the value as normal.

### **Voltage/Current Mode (mV/V/mA/A)**

Move the entry focus onto the level units to select between setting the pulse levels IN VOLTS or IN AMPERES.

**NOTE**

This parameter is only available in text mode.

### **Output Source Impedance Parameter (50Ω into)**

Select an output source impedance of 50 Ω or 1 kΩ

**NOTE**

This parameter is only available in text mode

### **Load Impedance Parameter (50.0Ω)**

Adjust the load impedance value expected at the output to compensate for non-50Ω loads. The displayed level parameters are then calculated using this value and therefore represent the levels at a non-50Ω static load.

**NOTE**

This parameter is only available in text mode.

## The Limits Screen

Use the Limits screen to set up voltage and current limits for the pulse level parameters to prevent accidental damage of the device under test.

To access the Limit screen, press the LIMIT softkey.

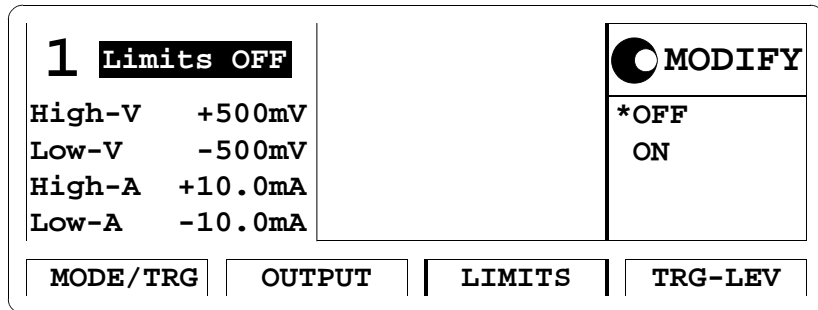

After you switch on the limits, the pulse level parameters on the OUTPUT screen cannot be adjusted outside the ranges specified on the LIMITS screen if the output is switched on. Note that because current and voltage limits apply, the available ranges of the impedance parameters are also affected.

When output limits are on, the limits are indicated on the OUTPUT screen in graphics mode, and the level bar is scaled accordingly:

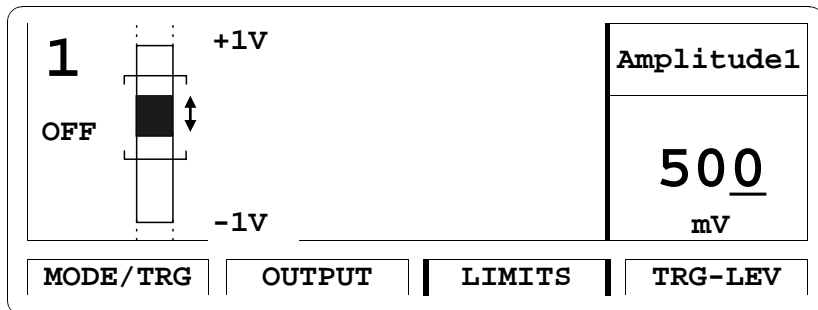



## The Trigger-Level Screen

Use the Trigger-Level screen to

- set the triggering threshold and input impedance for the EXT INPUT connector,
- set the triggering threshold and input impedance for the CLOCK/REF INP. connector,
- set the output levels for the STROBE OUT and TRIGGER OUT connectors.

To access the Trigger-Level screen, press the TRG-LEV softkey.

<b>EXT-IN: Threshold</b>	+1.0V 50Ω	<b>MODIFY</b> Set TTL Set ECL *Voltage	
<b>CLK-IN: Threshold</b>	+1.0V 50Ω		
<b>TRIGGER-OUT: TTL</b>			
<b>STROBE-OUT : TTL</b>			
<b>MODE/TRG</b>	<b>OUTPUT</b>	<b>LIMITS</b>	<b>TRG-LEV</b>

## Threshold and Impedance Parameters

You can individually specify threshold and input impedance of the EXT-IN and the CLK-IN connectors.

### EXT-IN and CLK-IN Threshold Parameters

Move the entry focus to EXT-IN or CLK-IN to quickly set the triggering threshold of the external input or the clock input to a TTL- or ECL-compatible level:

## The Trigger-Level Screen

- **SET TTL**  
Set the input threshold to +2.5 V.  
You can adjust the threshold by moving the entry focus to the value.
- **SET ECL**  
Set the input threshold to -1.3 V.  
You can adjust the threshold by moving the entry focus to the value.
- **VOLTAGE**  
Set any threshold level in the range of -10.0 V to +10.0 V. Move the entry focus to the value to adjust it.

## EXT-IN and CLK-IN Impedance Parameters

Toggle the input impedance of the external input connector or the clock input connector between 50  $\Omega$  and 10 k $\Omega$

## Trigger and Strobe Level Parameters

You can individually set the output levels of the TRIGGER OUT connector and the STROBE OUT connector.

Set the output levels (into 50  $\Omega$ ) to

- **TTL**  
High level: +2.50 V  
Low level: 0 V
- **ECL**  
High level: -0.85 V  
Low level: -1.80 V

---

## The Memory Card Screen

Use the Memory Card screen to

- store instrument settings to the memory card,
- recall instrument settings from the memory card,
- delete files from the memory card,
- format a memory card.

To access the Memory Card screen, press the MEMCARD softkey. If the MEMCARD softkey is not displayed, press MORE.

<b>Dir Path</b> \	 <b>MODIFY</b>
<b>Filename</b> TESTVI.TXT	<b>*BURSTS</b>
.....	<b>PULSES</b>
<b>Perform Operation</b>	
<b>MODE/TRG</b>	<b>TRG-LEV</b>
<b>MEMCARD</b>	<b>CONFIG</b>

### NOTE

Note that the HP 81101A uses DOS-formatted memory cards, and that you cannot create or delete directories using the instrument.

### Directory Path Parameter

Move the entry focus to DIR PATH to change the directory on the memory card, or to view the sub-directories of the current directory (the name of the current directory is displayed next to DIR PATH).

All sub-directories of the current directory are listed in the Modify/Enter area.

To change the directory, turn the knob to select the directory name and press the ENTER key.

Note that when you are in a sub-directory you can return to the parent-directory by selecting “..” from the directory list.

## **Filename Parameter**

Move the entry focus to the FILENAME parameter to select a file from the current directory. Use the knob to scroll through the filenames listed in the Modify/Enter area.

## **Memory Card Operations**

Move the entry focus to PERFORM OPERATION and use the knob to select the required operation. Press the ENTER key to perform the operation.

- READCARD  
Read the DOS file system information from the memory card after inserting a new card.
- RECALL  
Recall the selected file as the current instrument setting.
- STORE  
Store the current instrument setting to the memory card.  
Press ENTER once to start editing the filename for the setting in the Modify/Enter area. The currently selected filename is used as default.

---

### **CAUTION**

---

If you do not modify the filename, the existing file will be overwritten when you press ENTER.

To modify the filename, move the character cursor with the cursor keys. Modify a character using the knob. When you have finished, press ENTER to store the setting.

The filename can be up to 8 characters long.

Press the cursor up or cursor down keys to cancel the store operation at any time.

Note that the DOS filename suffix “.ST0” is added automatically to the filename when you store the current settings.

- **STORE ALL**

Store the current instrument setting and the instrument setting memories 1 to 9 to the memory card. Each setting is stored in a separate file with the same name but different suffixes (“.ST0” for the current setting, “ST1” to “ST9” for setting memories 1 to 9).

Press ENTER once to start editing the filename for the setting in the Modify/Enter area. The currently selected filename is used as default.

---

**CAUTION**

---

If you do not modify the filename, the existing file will be overwritten when you press ENTER.

To modify the filename, move the character cursor with the cursor keys. Modify a character using the knob. When you have finished, press ENTER to store the setting.

The filename can be up to 8 characters long.

Press the cursor up or cursor down keys to cancel the store operation at any time.

- **DELETE**

Delete the selected file from the memory card.

- **FORMAT**

Format the memory card.

---

**CAUTION**

---

Formatting a memory card destroys any existing files on the card.

## The Configuration Screen

Use the Configuration screen to

- set the HP-IB address of the HP 81101A,
- perform a selftest,
- select the frequency reference source and the frequency for the PLL.

To access the Configuration screen, press the CONFIG softkey. If the CONFIG softkey is not displayed, press MORE.

HP-IB Address: 10

Perform: Selftest

PLL-Ref : Internal

MODIFY

10

MODE/TRG | TRG-LEV | MEMCARD | CONFIG

### HP-IB Address

Set the HP-IB address for the instrument in the range of 0 to 30. The default address is 10.

### Perform Operation Selftest

Move the entry focus to PERFORM: SELFTEST and press the ENTER key.

If the selftest fails, a flashing E is displayed. Press HELP to see the list of error messages.

## **PLL Reference**

Set the frequency reference source for the PLL:

- **INTERNAL**  
The internal 5 MHz reference.
- **CLK-IN**  
An external reference signal at the CLOCK/REF INP. connector. You can set the expected frequency of the external reference to 5 MHz or 10 MHz.

## Warnings and Errors

The HP 81101A has two levels of error reporting called “warnings” and “errors”. Checking for errors and warnings is always enabled, unless you switch it off via the HP-IB using the :SYSTEM:CHECK command.

- A **warning** is generated when the output signal *could* be invalid due to a combination of worst case uncertainties at the current settings of all relevant parameters.

For example, when adjusting the pulse width, all other timing parameters (leading edge, trailing edge, and pulse period) and their uncertainties have to be considered in order to check if the width setting will fit within the pulse period.

Note that the warning limits are therefore not fixed for a particular parameter, but vary with the settings of the related parameters. It is also possible that the error and warning limits are the same, that is, a warning does not occur before the error limit is reached.

If a warning occurs, the settings are still implemented in the hardware because the worst-case conditions used to evaluate the warning limits are very unlikely to occur in practice.

A blinking W indicates that one or more warnings have occurred. Press HELP to view the warning list.

- An **error** is generated when an invalid mode is chosen, or the required parameter settings cannot be implemented in the output hardware. Multiple errors can occur, but only the first error detected is displayed.

An error is indicated by a blinking error message at the bottom of the screen.

### NOTE

If you are using the knob to adjust parameters it is normally not possible to generate warnings or errors. All parameters are automatically limited to settings that guarantee specified operation.

However, if you press the SHIFT key while turning the knob, you can adjust a parameter beyond its warning limits.



**NOTE**

You can press SHIFT + HELP (AUTOSET) to carry out an autoset. The instrument resets all parameters, based on the current period setting, to remove all warning and error conditions.

### **An Example of Warning and Error Reporting**

- 1** Switch on the instrument and recall the standard settings by pressing SHIFT + STORE (RECALL) + 0.

The period is now set to 1  $\mu$ s.

- 2** Switch on the output by pressing SHIFT + 0 (ON/OFF).

- 3** On the Output screen, move the parameter cursor to the value of the WIDTH parameter (100NS).

- 4** Use the knob to make the pulse width as large as possible (approximately 940NS).

This limit is intended to guarantee that the actual output pulse is within specifications, for the actual period.

The limit is calculated taking into account a worst case combination of minimum period from the period setting (1  $\mu$ s) and maximum width from the width setting (940 NS) together with minimum leading and trailing edge settings (5.00 NS).

**NOTE**

Note that if you now try to adjust the leading edge from its current setting of 5.00 ns with the knob, it cannot be adjusted. This is because the upper and lower warning limits are currently 5.00 ns. The width is at its maximum value and width + leading edge + trailing edge  $\leq$  period.

- 5** Press SHIFT and adjust the pulse width above its warning limit. A flashing W appears to indicate that a warning condition has occurred.

**NOTE**

Note that as long as no errors occur, the output hardware is set up and attempts to generate the required output.

- 6** Press HELP to see the warning message:

TRAILING EDGE 1 MAY CUT NEXT PULSE

- 7** Press HELP again to return to the WIDTH parameter.

- 8** Increase the pulse width further to approximately 980 ns and press HELP to see the current warnings:  
WIDTH 1 TOO CLOSE TO PERIOD  
TRAILING EDGE 1 MAY CUT NEXT PULSE
- 9** Press HELP again to return to the WIDTH parameter.
- 10** Increase the pulse width further until a flashing error message appears (approximately 1.10  $\mu$ s):  
OUTPUT 1: WIDTH > PERIOD  
You have reached the current upper error-limit of the WIDTH parameter.  
The setting is not implemented in the output hardware.
- 11** Press SHIFT + HELP to perform an AUTOSET.

---

**A**

---

# **Installation & Maintenance**

# Initial Inspection

Inspect the shipping container for damage. If the container or cushioning material is damaged, keep it until the contents of the shipment have been checked for completeness and the instrument has been verified both mechanically and electrically.

---

### **WARNING**

---

**To avoid hazardous electric shock, do not perform electrical tests when there are signs of shipping damage to any part of the instrument's outer covers or panels.**

If the contents are incomplete, or there is mechanical damage, or if the instrument does not work as expected within its specifications, notify the nearest Hewlett-Packard office. (Please request the latest performance tests from Hewlett Packard.) Keep the shipping materials for inspection by the carrier. The HP office will arrange for repair or replacement without awaiting settlement.

## Standard Deliverables

The HP 81101A shipping container contains the following standard deliverables:

1. The HP 81101A Pulse Generator.
2. The english Quick Start Guide and a Reference Guide.
3. A power cord.

### 1. HP 81101A Pulse Generator



### 2. This Quick Start Guide and the Reference Guide



### 3. A Power Cord



## Options and Accessories:

### Options

- |                       |  |
|-----------------------|--|
| Rear Panel Connectors | Option UN2<br>All inputs and outputs are at the rear panel |
| 1 MB SRAM Memory Card | Option UFJ<br>(HP part number 0950-3880)                   |

The following figure shows the instruments rear panel with Option UN2 installed.

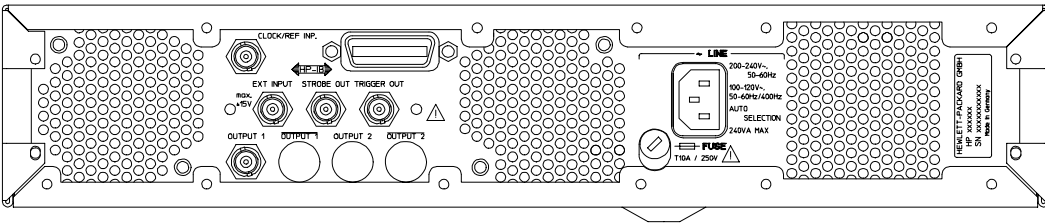

### Handle Accessory

- |                  |                          |
|------------------|--------------------------|
| Front Handle Kit | HP part number 5063-9226 |
|------------------|--------------------------|

### Rack Mounting Accessories

- |                                 |                          |
|---------------------------------|--------------------------|
| Rack Mount Kit                  | HP part number 5063-9212 |
| Rack Mount and Front Handle Kit | HP part number 5063-9219 |
| Rack Slide Kit                  | HP part number 1494-0059 |

## Quick Start Guide Language Options

French Guide	Option ABF (HP part number 81101-91210)
Japanese Guide	Option ABJ (HP part number 81101-91510)
Taiwan Chinese Guide	Option AB0 (HP part number 81101-91610)
Korean Guide	Option AB1 (HP part number 81101-91710)
Chinese Guide	Option AB2 (HP part number 81101-91810)

## Additional Documentation Options

Service Manual	Option 0BW (HP part number 81101-91021)
Service Documentation (Component Level)	HP part number 81101-91031

---

## Power Requirements

---

**CAUTION**

Before applying AC line power to the instrument, ensure that the correct line fuse is installed in the fuse holder and the correct power cable is fitted.

---

**NOTE**

When the front panel switch is off, the instrument is in “standby” mode. The instrument is disconnected from the AC line power *only* by disconnecting the power cord. Please make sure that the power cord is easily identifiable and can quickly be reached by the operator.

The following symbol is close to the ‘Standby’ switch on the front panel of the instrument.



The instrument can operate from any single-phase AC power source supplying 100–240 V in the frequency range from 50 to 60 Hz, or 100–120 V at 400 Hz. The maximum power consumption is 300 VA with all options installed. When the instrument is switched on the power supply adapts automatically to the applied AC power (Auto Selection) and monitors the AC power range during operation.



## Replacing the Fuse



- 1 Remove the power cord.
- 2 Unscrew the fuse cap at the rear of the instrument beside the power-inlet socket.

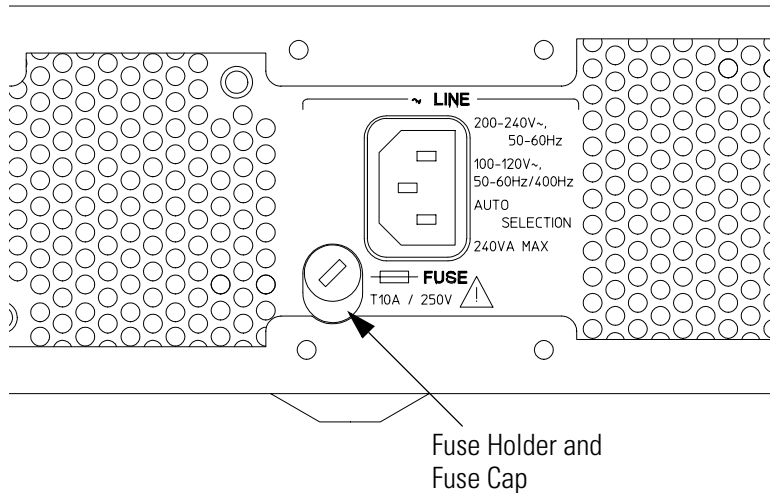

- 3 Replace the fuse with the equivalent part:

Line Voltage	Fuse Type	HP Part Number
100-240 V~	T 10A, 250 V	2110-0720

- 4 Refit the fuse cap.

## Power Cable

In accordance with international safety standards, this instrument is equipped with a three-wire power cable. The figure below shows the part numbers of the power cables available. When connected to an appropriate AC power receptacle, this cable grounds the instrument cabinet.

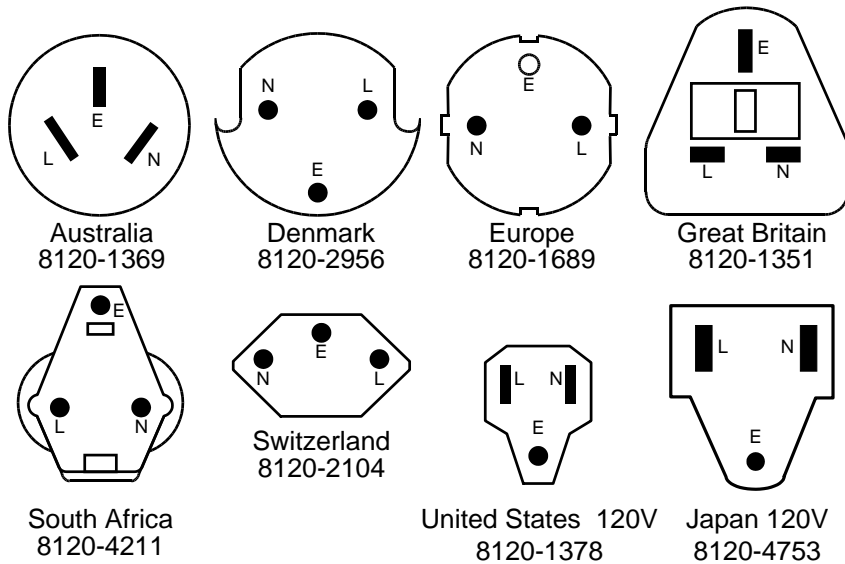

## Ventilation Requirements

The instrument is fitted with three cooling fans. Make sure that there is adequate clearance of 80 mm at the rear and 25 mm at the top and bottom to ensure adequate air flow. If the air flow is restricted, the internal operating temperature will be higher, reducing the instrument's reliability or causing the instrument's thermal-protection circuits to automatically switch off the instrument.

### **NOTE**

Do not cover the ventilation holes.

## Thermal Protection

### Overheating Detection

The instrument monitors its internal temperature. If the temperature exceeds approximately 80°C, the power supply is switched off. The instrument will switch on again if the temperature falls below approximately 77°C.

### Fan Failure

If a fan is broken or prevented from operating by a blockage, the temperature will increase. When the temperature exceeds approximately 80°C the overheating detection switches off the instrument for safety reasons. For reliability it is recommended to send instruments with broken or defective fans immediately to HP Service for repair.

## Battery



This instrument contains a lithium battery. Typical life time of the battery is about 5 years.

**NOTE**

Recycle or dispose used batteries according to local regulations. Or contact your Hewlett-Packard representative for information on battery recycling.

(In the USA and Canada, call 1-800-333-1917)

The battery is replaceable. Replacement should only be carried out by *qualified service personnel*.

**NOTE**

There is a danger of explosion if the battery is incorrectly replaced.

The battery must be replaced with the same or equivalent battery type:

A **Lithium CR2477-N** type battery.

The HP replacement part number is: **1420-0557**.

The battery is protected against charging.

---

**CAUTION**

---

Do *not* crush, puncture, or incinerate the battery. Do *not* short the battery's external contacts.



## Battery Replacement

### NOTE

Disconnect the power cord from AC line voltage to avoid electrical shock.

- 1 Remove the bumper which is fitted to the front panel.**
- 2** Remove the strips on the left and right side of the front panel.
- 3** Remove the front panel which is secured with two screws at each side.
- 4** Disconnect the flat cable which connects the front panel to the chassis.
- 5** On the right side of the chassis there is a cover secured with one screw. Remove this cover.
- 6** Now the battery can be removed from the battery holder. It is recommended to push the battery on the top, and to pull the battery on the bottom with one finger for easier removal.
- 7** Fit the new battery in the holder, take care to not short current the battery on the chassis.
- 8** Fit the cover again and secure it with the screw to the chassis.
- 9** Re-connect the flat cable of the front panel again to the chassis connector. Make sure that the pin one (red wire) is pointing to the mid of the chassis.
- 10** Re-assemble the front cover.
- 11** Fit the strips to the sides of the front panel, again.
- 12** Fit the bumper to the front panel.

## Operating Environment

---

Storage Temperature	-40 °C to +70 °C
Operating Temperature	0 °C to 55 °C
Humidity	95% R.H. (at 40 °C)
Altitude	Up to 2000m
Installation	Category II
Pollution	Degree 2

---

---

### **WARNING**

**The instrument is not designed for outdoor use. Do not expose the instrument to rain or other excessive moisture. Protect the instrument from humidity and temperature changes which could cause condensation within the instrument.**

**Do not operate the instrument in the presence of flammable gases, fumes or powders. Operation of any electrical instrument in such an environment constitutes a definite safety hazard.**

---

---

## Cleaning Recommendation

---

**WARNING**

To prevent electrical shock, disconnect the instrument from mains before cleaning. Use a dry cloth or one slightly dampened with water to clean external case parts. Do not attempt to clean internally.

---

## **Acoustic Noise Emission**

### **Acoustic Noise Emission**

For ambient temperatures up to 30°C, under normal operation and at the typical operator position:

LpA = 52 dBA

Measured in accordance with ISO 7779 / EN 27779.

### **Geräuschemissionswerte**

Bei einer Umgebungstemperatur bis 30°C

LpA = 52 dBA

an Arbeitsplatz, normaler Betrieb.

Angabe ist das Ergebnis einer Typprüfung nach ISO 7779 / EN 27779.



# Index

## A

- Accessories 78
- Acoustic Noise Emission 88
- Additional Documentation 79
- Amplitude Parameter 62
- Automated Testing 17
- Autoset 26, 73

## B

- Battery 84
  - disposal 84
  - for memory back-up 84
  - replacement 85
  - type 84
- Benefits 16
- Burst Mode
  - continuous 47
  - gated 54
  - triggered 50
- Burst Signal
  - command list 42
  - example 39

## C

- Cable 82
- Capabilities
  - signal generation 16
- Certification
  - met specifications 5
- Cleaning Recommendation 87
- Clock Signal
  - command list 34
  - example 30
- CLOCK/REF INP. connector 28
- Command Language 17
- Command List
  - burst signal 42
  - clock signal 34
  - pulse signal 38
- Conditions, environmental 86
- Configuration Screen 70
- Connectors
  - front panel 18
  - rear panel 28
- Continuous Mode
  - burst 47
  - pulses 46
- Current limits 64

## D

- Digits 25
- Directory 67
- Documentation, additional 79

## E

- Emission
  - acoustic noise 88
- Environmental Conditions 86
- Error checking 72
- Errors 26, 72
- Examples
  - burst signal 39
  - clock signal 30
  - pulse signal 35
- Exceed
  - Specified Values 25
- EXT INPUT
  - front panel 19
  - Impedance 66
  - rear panel 28
- EXT INPUT Threshold 65
- External PLL Reference 70
- External Width Mode 55

## F

- Features 16
- Front Panel 18

## G

- Gating
  - gated burst mode 54
  - gated pulses mode 52
  - manual 26
  - sources 45
- Graphical Display 22

## H

- Handle Accessory 78
- Help Information 26
- High Accurate Frequency 45
- High Level Parameter 62
- HP-IB
  - Address 70
  - automated testing 17
  - connector 28

## I

- IC Technologies 16
- Input Impedance 66

# Index

Inspection 76  
Installation 76

## K

Knob 18

## L

Language Options 79  
Leading Edge Parameter 59  
Level Parameters 61  
Limits  
    overprogramming 25  
    screen 64  
Line Fuse 80  
Load Impedance Parameter 63  
LOCAL key 26  
Logic Technologies 16  
Low Level Parameter 62

## M

MAN Key 26, 48, 50, 52, 54  
Memory Card Screen 67  
Modify  
    resolution 25  
Modify Knob 18  
MORE key 18

## N

Normal/Complement Parameter 62

## O

Offset Parameter 62  
On-line Help 26  
Operating Environment 84, 86  
Options 78  
OUTPUT connector 19  
Output Screen 56  
Output Source Impedance Parameter 63  
Overprogramming 25

## P

Parameter  
    step size 25  
Parameters  
    levels 61  
    timing 56  
Path 67  
PLL 45  
    reference source 71  
PLL Reference 70

Power Cable 82  
Power Consumption 80  
Power Cord 77, 82  
Power Requirements 80  
Power Source 80  
Product Features 16  
Pulse Capabilities 16  
Pulse Delay Parameter 58  
Pulse Period  
    parameter 57  
    source 45  
Pulse Signal  
    command list 38  
    example 35  
Pulse Trailing Edge Parameter 60  
Pulse Width Parameter 59  
Pulses Mode  
    continuous 46  
    gated 52  
    triggered 48

## R

Rack Mounting 78  
Rear Panel 28  
Recalling Settings  
    internal memory 26  
    memory card 67  
Remote  
    control 17  
    programming 17  
    unlock 26  
Resolution 25  
Rotary Knob 18

## S

Safety  
    instructions 8  
    symbols 9  
SCPI 17  
Selftest 70  
Service Documentation 79  
Shift Key 25, 26  
Signal Generation Capabilities 16  
Standard Deliverables 77  
Standby Switch 80  
Startable Oscillator 45  
Storing Settings  
    internal memory 26  
    memory card 67

# Index

STROBE OUT connector 19  
Switch, standby 80

## T

Threshold 65  
Timing Parameters 56  
Timing Variations  
  dropout free 16, 56  
  glitch free 16, 56  
TRIGGER OUT connector 19  
TRIGGER OUT levels 66  
Triggering  
  manual 26  
  sources 45  
  triggered burst mode 50  
  triggered pulses mode 48  
Trigger-Level Screen 65

## U

Unlock Front Panel 26  
Use Models 16

## V

Ventilation Requirements 83  
VFO 45  
Voltage limits 64  
Voltage/Current Mode Parameter 63

## W

Warnings 26, 72

# Index

# Front Panel Controls

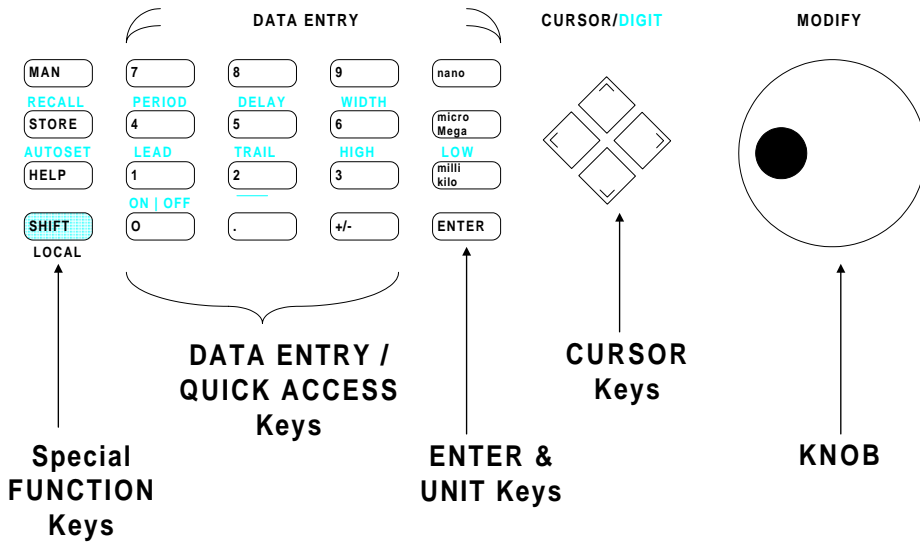

Hewlett-Packard GmbH  
Copyright © 1998  
Edition E0998  
Printed in Germany, September 1998

<BAR CODE to go here>  
81101-91010